

Details and Detailing of Concrete Reinforcement (ACI 315-99)

Reported by ACI Committee 315

Ronald D. Flach
Chairman

Anthony L. Felder
Secretary

Michael Baynard

Paul Gordon

A. Murray Lount

Miguel R. Casias

Edward S. Hoffman

Peter Meza

Robert E. Doyle

David W. Johnston

Vasant C. Mistry

Gustav G. Erlemann

Robert W. Johnson

Roy H. Reiterman

Gerald E. Goettsche

Harry B. Lancelot, III

Milton R. Sees

Douglas D. Lee

This document provides standards of practice for both the architect/engineer (A/E) and reinforcing steel detailer in showing reinforcing steel details. It is divided into three parts: one addressed to the A/E, one for the detailer, and a third providing a reference table and figures. It defines the responsibilities of both the A/E and detailer. It then establishes certain standards of practice for both the structural and placing drawings.

Keywords: beams (supports); bending (reinforcing steels); bridges (structures); buildings; columns (supports); concrete slabs; detailing; drafting (drawing); fabrication; floor systems; foundations; hooked reinforcing steels; microcomputers; placing drawings; reinforced concrete; reinforcing steels; splicing; stirrups; structural design; structural drawings; ties; tolerances (mechanics); walls; welded-wire fabric.

CONTENTS

Part A—Responsibilities of the architect/engineer Chapter 1—Structural drawings, p. 315-2

- 1.1—General
- 1.2—Drawing standards
- 1.3—Structural drawings—Buildings and other structures
- 1.4—Structural drawings—Highway and transportation structures

Chapter 2—Standards of practice, p. 315-3

- 2.1—General
- 2.2—Tolerances
- 2.3—Bar lengths
- 2.4—Hooks and bends
- 2.5—Beams and girders
- 2.6—Columns
- 2.7—Development and splices of reinforcing steel
- 2.8—Joint details
- 2.9—Reinforcing steel supports
- 2.10—Special details for seismic design of frames, joints, walls, diaphragms, and two-way slabs
- 2.11—Corrosion-resistant coatings for reinforcing steel

Part B—Responsibilities of the detailer Chapter 3—Placing drawings, p. 315-10

- 3.1—Definition
- 3.2—Scope
- 3.3—Procedure
- 3.4—Drawing standards
- 3.5—Building drawings
- 3.6—Highway drawings
- 3.7—Detailing to fabricating standards

Chapter 4—Fabricating practice standards, p. 315-15

- 4.1—Fabrication
- 4.2—Extras
- 4.3—Tolerances

Chapter 5—Supports for reinforcing steel, p. 315-16

- 5.1—General
- 5.2—Types of bar supports
- 5.3—Side form spacers and beam bolsters
- 5.4—Placing reinforcing steel supports

Chapter 6—Computer-assisted detailing, p. 315-16

- 6.1—Use of computers in detailing
- 6.2—Placing drawings
- 6.3—Ordering procedures

Chapter 7—Recommended practices for location of bars designated only by size/spacing, p. 315-17

ACI 315-99 supersedes ACI 315-92 and became effective August 31, 1999.
Copyright © 1999, American Concrete Institute.

All rights reserved including rights of reproduction and use in any form or by any means, including the making of copies by any photo process, or by electronic or mechanical device, printed, written, or oral, or recording for sound or visual reproduction or for use in any knowledge or retrieval system or device, unless permission in writing is obtained from the copyright proprietors.

Chapter 8—Glossary, p. 315-17**Chapter 9—References, p. 315-18**

- 9.1—Reference standards
- 9.2—Cited references

Chapter 10—Notations, p. 315-19**Part C—Figures and tables, p. 315-20****FOREWORD**

Increased use of computers has led to sophisticated techniques of structural analysis and has increased manufacturing and fabrication capabilities. This added degree of sophistication has resulted in more complex structures being designed and built with structural members that have long spans, shallow depths, and contain a high percentage of reinforcing steel.

In the past, during the course of developing placing drawings, the detailer often suggested solutions in areas where the details were incomplete and where the reinforcing steel appeared to have constructability problems. Usually these solutions were used only after their acceptance by the architect/engineer (A/E). Unfortunately, many problems do not surface during the detailing phase but rather occur during construction. The A/E and the contractor, working together, then solve the problem.

The A/E prepares the structural design to meet the requirements of the applicable building code and provides sufficient definition through the contract documents to convey all the requirements for detailing reinforcing steel. It is then the detailer's responsibility to develop all of the dimensions and quantities of the reinforcing steel to conform with the structural drawings and project specifications of the A/E.

As the complexity of design and construction increases, it is imperative that both the A/E and detailer understand their responsibilities clearly. The responsibilities of the A/E and the detailer, as they apply to the reinforced-concrete industry, are stated more clearly by the following separate sections.

This standard presents values in inch-pound and SI units. Hard metric values are usually not exact equivalents; therefore, each system is to be used independently of the other. Combining inch-pound and hard metric values can result in nonconformance with the standard. Soft metric values are exact equivalents, so combining inch-pound and soft metric values conforms to the standard.

PART A—RESPONSIBILITIES OF THE ARCHITECT/ENGINEER**CHAPTER 1—STRUCTURAL DRAWINGS****1.1—General**

Structural drawings are those prepared by the A/E for the owner or purchaser of engineering services. The structural drawings and the project specifications form a part of the contract documents. Structural drawings must contain an adequate set of notes and all other essential information in a form that can be quickly and correctly interpreted. These drawings must convey definite instructions and show rein-

forcing bars and welded-wire fabric. Structural and placing drawings may be combined.*

The responsibility of the A/E is to furnish a clear statement of design requirements to the detailer. The A/E's project specifications or structural drawings must not merely refer the detailer to an applicable building code for information to use in preparing the placing drawings. Instead, this information shall be interpreted by the A/E and shown in the form of specific design details or notes for the detailer to follow. Where omissions, ambiguities, or incompatibilities are discovered, additional information, clarifications, or corrections shall be requested by the detailer and provided by the A/E. The A/E should require in the specifications that placing drawings be submitted for approval.

Section 1.2.1 of ACI 318 (318M), Building Code Requirements for Structural Concrete, lists the information that shall be presented on the structural drawings or in the project specifications, which includes the following:

1. Anchorage length of reinforcing steel and location and length of lap splices; and
2. Type and location of mechanical and welded splices of reinforcing steel.

1.2—Drawing standards

1.2.1 Materials—The minimum standard media for production of structural drawings should be penciled on tracing paper. Other media providing improved reproducibility or durability, such as microfilm, electronic files, ink, tracing cloth, or polyester film, can also be used.

1.2.2 Sizes—Drawings should be made in standard sizes. All sheets in any one set of drawings should be the same size. There are two well-recognized sets of standard sizes.

Commercial standards:

- 18 x 24 in. (457 x 610 mm)
- 24 x 36 in. (610 x 914 mm)
- 27 x 36 in. (686 x 914 mm)
- 30 x 42 in. (762 x 1067 mm)

Federal agencies:

- 17 x 22 in. (432 x 559 mm)
- 22 x 34 in. (559 x 864 mm) + 2 in. (51 mm) binding (AASHTO)
- 28 x 40 in. (711 x 1016 mm) + 2 in. (51 mm) binding
- 30 x 42 in. (762 x 1067 mm)

All dimensions are to the cutting line outside the margin. Border lines are inside these dimensions. Requirements for placing drawings are in **Part B**, addressed to the detailer.

1.2.3 Direction—An arrow indicating the direction of North should be placed on every drawing that contains a plan view.

1.2.4 Scales—The scales used should be indicated on all structural drawings, preferably under the title of each view. Drawings that can be enlarged or reduced in reproduction should show a graphic scale, as well as a descriptive one, to aid the user.

1.2.5 Lettering—All lettering must be clear and legible. If reduced-scale photographic prints are made for field use, lettering

*Requirements for placing drawings are in Part B, addressed to the detailer.

must be correspondingly larger and meet microfilming standards in accordance with the Association for Information and Image Management (formerly the National Microfilm Association) publication “Modern Drafting Techniques for Quality Microreproductions.”

1.3—Structural drawings—Buildings and other structures

1.3.1 General—Structural drawings and project specifications for elements such as beams, girders, columns, walls, and foundations shall show the type and grade of reinforcing steel, any special coatings, service live load, partition, ceiling and hanging loads, or any special dead loads other than the self-weight (mass) and concrete strength. Structural drawings and project specifications shall also show concrete dimensions, anchorage length of reinforcing steel and location and length of lap splices, type and location of mechanical and welded splices of reinforcing steel, concrete cover for the reinforcing steel, required joints, and any other information needed for the preparation of the placing drawings. Sleeve locations and any special reinforcing steel around sleeves or openings shall be indicated by the A/E. See Fig. 1, 2, 3, 4, 5, 6, and 7 (in Part C—Figures and Tables), for examples. In addition to these requirements, structural drawings of beams, girders, and columns must also show the information presented below.

1.3.2 Beams and girders—Schedules for beams and girders must contain the beam mark, size of member, number and size of straight and bent bars, special notes on bending, number, size, and spacing of stirrups or stirrup-ties, location of top bars, and any special information, such as the requirement of two layers of reinforcing steel. Show sections for beam-column joints, where necessary.

In continuous beams, the number and spacing of top bars to be placed in T-beam flanges (slabs) for crack control shall be shown, if so required by the design.

1.3.3 Columns—Column designs shall show the size of columns, number, locations, grade, and size of reinforcing steel, and all necessary details where column section or reinforcement changes. Method of splicing shall always be defined clearly, showing arrangement of splices, type (lap, mechanical or welded), length (if lap splice), and stagger. Orientation of reinforcing steel in two-way symmetrical columns shall be shown when reinforcing steel is not two-way symmetrical.

1.4—Structural drawings—Highway and transportation structures*

1.4.1 Dimensions—Because the structural drawings for highway structures usually are a combination of structural and placing drawings from which the structure will be built, all dimensions must be shown clearly. Drawings must show the dimensions of concrete protection for all reinforcing steel.[†] Where separate placing drawings are prepared, structural dimensions may be omitted, following the same practice as for buildings (see Section 3.5).

1.4.2 Reinforcing steel—Combination structural-placing drawings shall show the size, spacing, and location of the

bars and welded-wire fabric in the structure. The list of bars must show the number of pieces, size, length, mark of bars, and bending details of all bent bars. The list of welded wire fabric must show the mark, style, width, length, and number of pieces.

Reinforcing steel for larger structures is sometimes detailed, fabricated, and delivered by units, for example, footings, abutments, piers, and girders. The reinforcing steel list may be subdivided similarly. If the structure is sufficiently large, a separate drawing and reinforcing steel list is usually made for each unit.

Reinforcing steel for foundations, piers, abutments, wing walls, and slabs are usually shown on a plan, section, or elevation view on the drawings. Cross sections must be provided for clarification where necessary. The reinforcing steel list is a complete summary of materials required. All bars should appear at least once in a plan or elevation view and in a sectional view, or both.

For reference data on reinforcing bars and welded wire fabric from industry sources, refer to the Supporting Reference Data section. This section includes specific information on applicable ASTM specifications, coated reinforcing bars, common styles and design data for welded wire fabric, and reinforcing bar supports.

CHAPTER 2—STANDARDS OF PRACTICE

2.1—General

This chapter provides the A/E with minimum standards for application during the development of the design. Information presented here is a collection of notes derived from ACI 318 (318M); ACI 343R; AREMA *Manual for Railway Engineering*, Chapter 8, “Concrete Structures and Foundations;” and AASHTO “Standard Specifications for Highway Bridges;” industry practice, practical considerations, and research results current at the time of this report. Reinforcing steel for structures designed under the provisions of ACI 349, ACI 359, and other similar documents can generally incorporate the direction given in this standard unless otherwise prohibited by the provisions of the respective related documents.

2.2—Tolerances

ACI 117 provides standard tolerances for concrete construction. Practical limitations of equipment and production efficiency have led to the establishment of certain fabrication tolerances that can be met with standard shop equipment. These standard tolerances are shown in Fig. 8 and 9 (in Part C) for both straight and bent bars. Where more restrictive tolerances are required than those shown in the referenced figures, they shall be indicated in the contract documents. The effects of tolerances on cover, strength, constructability, and serviceability of the structure should be considered by the A/E.

2.3—Bar lengths

Placing drawings and bar lists must show all bar dimensions as out-to-out with bar lengths as the sum of all detailed dimensions, including hooks A and G (Table 1 in Part C).

*The term “highway and transportation structures” used herein includes bridges, drainage, and related structures.

[†]Subject to requirements of ACI 318 (318M), Section 7.7, or the AASHTO bridge specifications, Articles 8.22 and 9.26.

2.4—Hooks and bends

Hooks and bends are specified to standardize the fabrication procedure and to limit the concrete stresses in the area of the hooks. See [Table 1](#) and [Fig. 10](#) in Part C.

2.5—Beams and girders

2.5.1 Beam widths—To permit satisfactory placing of concrete and to furnish adequate concrete protection, the A/E must provide for adequate clear distance between parallel bars and between bars and forms.

The A/E must specify the required concrete protection for the reinforcing steel. The A/E must also specify the distance between bars for development and concrete placing. For buildings, the clear space is the larger of one bar diameter, 1-1/3 the maximum size of coarse aggregate to be used, and 1 in. (25 mm). For cast-in-place bridges, required clear space is the larger of 1.5 bar diameters, 1.5 maximum size aggregate, and 1.5 in. (40 mm).

Tables in the supporting reference data section give a wide range of beam widths and the maximum number of bars permitted in a single layer for 3/4 and 1 in. (20 and 25 mm) maximum aggregate size as provided by ACI 318 (318M).

Other tables in the supporting reference data section similarly give the same information for beams designed under the provisions of the AASHTO bridge specifications. These tables are provided for the use of the A/E; the detailer is not in a position to determine whether bars should be permitted to be placed in more than a single layer.

2.5.2 Stirrup anchorage—The A/E shall show or specify by notes the sizes, spacings, location, and types of all stirrups. These types include open stirrups and closed stirrups (or stirrup-ties) ([Fig. 11](#) and [12](#) in Part C). Stirrups are most often fabricated from reinforcing bars, but may also be fabricated from welded-wire fabric.

There are various permissible methods of anchorage, but the most common is to use one of the standard stirrup-tie types as shown in [Fig. 10](#). Types S1 through S6, T1, T2, and T6 through T9 standard tie and stirrup hooks are shown in [Table 1](#). Where stirrup support bars are required, they must be specified by the A/E. In designing the anchorage, allowance must be made to ensure that the ends of the stirrup hook are fully encased in concrete, as when hooks turn outward into shallow slabs.

Where the design requires closed stirrup-ties for shear, the closure may consist of overlapped, standard 90 degree end hooks of one- or two-piece stirrups, or properly spliced pairs of U-stirrups. Where the design requires closed ties for torsion, the closure may consist of overlapped, standard 135 degree hooks of one- or two-piece ties enclosing a longitudinal bar. At least one longitudinal bar shall be located inside each corner of the stirrups or ties, the diameter of this bar to be equal to at least the diameter of the stirrup (No. 4 [No. 13] minimum). Ties provided to resist radial forces resulting from bar or tendon curvature shall be anchored adequately.

2.5.3 Spacings of bundled bars—When bars are placed in contact with each other in groups of two, three, or four—known as bundled bars—the minimum clear space provided between bundles for buildings under ACI 318 (318M) shall be equal to the diameter of a single, round bar having an area

equivalent to the area of the bundle. For bridge design, the AREMA design manual and the AASHTO bridge specifications require a minimum spacing equal to 1.5 times diameter of a single, equivalent area bar.

2.6—Columns

2.6.1 Column verticals—In selecting reinforcing steel for columns, consideration shall be given to the minimum spacing of bars or bundles required by ACI 7.6.3.* Tables in the supporting reference data section show the maximum number of bars for round columns and the maximum number of bars that can be placed in one face of a rectangular column. Splice arrangements shall be shown. For butt-spliced systems, an allowance must be included for an increase in diameter at mechanical splices and for access to welding. Special end preparation required for bars must be shown or specified. Where the reinforcing steel area required above is different from that in the column below, the structural drawings must clearly show the extension required (if any) of all reinforcing bars above and below the floor level (see also [Section 2.7](#)).

2.6.2 Offset between column faces—Where there is a change in size of a column, the structural drawings must show how the vertical bars are to be offset, or separate dowels must be shown (see [Section 3.7.7.2](#)). The slope of the inclined portion providing the offset shall not exceed one in six. See [Fig. 4](#) for recommended splicing details.

Where column verticals are offset bent, additional ties are required and shall be placed not more than 6 in. (150 mm) from the point of the bend. For practical purposes, three closely spaced ties are usually used, one of which may be part of the regularly spaced ties, plus two extra ties. General arrangements of vertical bars and all tie requirements shall be established by the structural drawings.

In addition to showing size and regular spacing of column ties, the A/E shall also show any additional ties required for special conditions, such as splices and offset bends.

2.6.3 Changing bar arrangement between floors—When the bar arrangement is changed at a floor, the bars may extend through, terminate, or require separate dowels. Reinforcing steel at least equal in area to that in the column above must be extended from the column below to lap bars above by the required lap length or butt splices must be provided. Vertical bars from the column below, terminated for any reason, are cut off within 3 in. (75 mm) of the top of the finished floor unless otherwise indicated on the structural drawing. The A/E shall determine what, if any, additional extension of discontinued column verticals is required for adequate embedment, and show this information on the structural drawings.

2.6.4 Spirals—Pitch or spacing of spirals should be given to the nearest 1/4 in. (5 mm). According to ACI 318 (318M), the clear spacing between spiral turns shall not exceed 3 in. (80 mm) or be less than 1 in. (25 mm) or 1-1/3 times the maximum size of coarse aggregate used. Spirals shall be provided with 1-1/2 extra turns at both top and bottom. If necessary to

*Reference to ACI 318 (318M) is given as "ACI" followed by the number of the section.

splice a spiral, it shall be done by a lap splice of $48d_b$ or by welding.

Minimum diameters to which standard spirals can be formed and minimum diameters that are considered collapsible are shown below for various sizes of spiral bars. Plain or deformed bars or wire can be used to manufacture spirals.

Spiral bar diameter, in. (mm)	Minimum outside diameter that can be formed, in. (mm)	Minimum outside diameter of collapsible spiral, in. (mm)
3/8 (10)	9 (225)	14 (350)
1/2 (13)	12 (300)	18 (450)
5/8 (16)	15 (375)	24 (600)
3/4 (19)	30 (750)	—

Spirals are used primarily for columns, piers, and drilled caissons, but are also used in piles. Continuously wound, reinforcing steel in the form of a circular helix not meeting ACI 318 (318M) definition of a spiral may be used in these structures as tie reinforcement. Such reinforcing steel, sometimes referred to as continuous ties, is usually specified with a large pitch.

2.6.5 Column ties—The vertical bars in tied columns shall be tied together laterally. Standard arrangements of ties for various numbers of vertical bars are shown in Fig. 13 and 14 in Part C. The A/E may also specify welded-wire fabric with an equivalent area of reinforcing steel for column ties. The arrangements of one-piece ties shown in Fig. 13 provide maximum rigidity for column cages preassembled on the site before erection. Preassembly is preferred only for the common designs employing one-story-length vertical bars all lap spliced at or near one point above the floor line. See Section 2.7.3 for lap splice restrictions.

With staggered butt splices on large vertical bars in two-story lengths, practical erection limitations usually require that column ties be assembled on free-standing vertical bars. Standard arrangements for two-piece column ties shown in Fig. 13 and 14 are recommended to facilitate field assembly. They are universally applicable to any splice arrangement required by the A/E. If access to the interior of a column or a pier is necessary, or if the A/E prefers, some other pattern of ties may be substituted, provided that the tie arrangement meets ACI 318 (318M) requirements.

The spacing of ties depends on the sizes of vertical bars, columns, and of ties. The maximum spacings permitted are shown in a table in the supporting reference data section.

In addition to showing size and regular spacing of column ties, the A/E shall also show any additional ties required for other special conditions such as at splices, and offset bends (see also Section 2.10 for seismic details).

If the design requires lateral reinforcement in the column between the top of the main spiral and the floor level above, it may be provided by a stub spiral (short section of spiral) or circular column ties to permit placing of the reinforcing steel in the floor system, and the arrangement shall be shown.

2.6.6 Bundled bars—Bundled bars can be used as column verticals. A bundle is defined as a group of parallel bars bundled in contact to act as a unit. Not more than four bars can be grouped into one bundle. Butt splices or separate splice bars should be used.

Bundled bars must be tied, wired, or otherwise fastened to ensure that they remain in position. All bundles of column verticals must be held by additional ties above and below the end-bearing mechanical splices and any short splice bars added for tension should be tied as part of the bundle within the limitation of the number of bars in a bundle. Bundled bars shall be enclosed within ties. Ties smaller than No. 4 (No. 13) for bundled bars shall not be used. Design and detail information on bundled bars as column verticals is provided in a table in the supporting reference data section.

2.7—Development and splices of reinforcing steel

2.7.1 General—In ACI 318 (318M), development and lap splice lengths for deformed reinforcing bars can be calculated using one of two optional approaches. A previous calculation approach, from ACI 318-89 (318M-89) also remains acceptable. With multiple code-compliant approaches to calculation existing, choice, interpretation, and application are the A/E’s responsibilities. Sufficient information shall be presented on the structural drawings and in the project specifications to allow detailing of bars at splices and embedment locations without referencing back to the code.

Tables in the supporting reference data section give values of tension development lengths and tension lap splice lengths of straight bars. Values of tension ℓ_d and tension lap splice lengths in the tables are based on the provisions in ACI 12.2.2. All tabulated data are for Grade 60 (420) reinforcing bars in normalweight concrete with the concrete compressive strength, f'_c , ranging from 3000 to 8000 psi (21 to 56 MPa).

The tables use the terminology Cases 1 and 2. Cases 1 and 2, which depend on the type of structural element, concrete cover, and the center-to-center spacing of the bars, are also defined in the tables.

Separate tables are included for uncoated and epoxy-coated bars. There are no special development requirements in ACI 318 (318M) for zinc-coated (galvanized) bars and they should be treated as uncoated bars. For lightweight aggregate concrete, the values in the tables would have to be modified by the applicable factor (ACI 12.2.4).

ACI 1.2.1 requires that anchorage length of reinforcement and location and length of lap splices be shown on the structural drawings. This information can be shown by dimensioning cut-off locations and including tables of applicable lap splice lengths.

2.7.2 Splices, general—In beams or girders that require bars longer than can be carried in stock, splices shall be specified. The A/E shall show or specify by notes how the splicing is to be realized; namely, lap splices, mechanical splices, or welded splices.

The A/E shall also show, by details on structural drawings, the location and length of all splices. In beams or girders, splices should preferably be made where the stress in the bar

is minimum, that is, at the point of inflection. Splices where the critical design stress is tensile should be avoided by the A/E wherever possible. Lapped bars may be either in contact or separated. The A/E shall show or note on the structural drawings whether splices are to be staggered or made at the same location. Bars to be spliced by noncontact lap splices in flexural members shall not be spaced transversely more than the smaller of one-fifth the length of lap and 6 in. (150 mm).

2.7.3 Lap splices—It is necessary for the A/E to show the location and length of lap splices because the strength of a lap splice varies with the bar diameter, concrete strength, bar spacing, concrete cover, position of the bar, distance from other bars, and the type of stress (compressive or tensile). Where bars of two sizes are lap spliced, the A/E must indicate the appropriate lap splice length. Lap splices are not permitted for No. 14 and 18 (No. 43 and 57) bars, except for transferring compression to smaller size dowels that are anchored into footings for buildings. Lap splices for bars larger than No. 11 (No. 36) are not permitted by the AREMA design manual or the AASHTO bridge specifications.

At column bar splice locations, sufficient bars (or dowels) from the lower columns must extend into the upper column to provide not less than the cross-sectional area of the required bars in the upper column. These bars must extend the minimum distance required for lap splices. The A/E should note that unless otherwise specified or shown on structural drawings, the detailer will detail the remaining bars in the lower column extending to within 3 in. (75 mm) of the top of the floor or other member transmitting the additional load to the column. Where the top ends of column bars are less than 6 ft (1800 mm) above the top of footings or pedestals, the bars should extend into the footings or pedestals. Normally, dowels will be used only if specifically noted on structural drawings.

Dowels for lap splices at column offsets should have a cross-sectional area at least equal to that of the bars above and they shall extend both above and below the splice locations, as specified by the A/E.

The A/E should also be aware that it is a standard practice in the industry when detailing column verticals to use the appropriate lap splice length for the bars in the column above. This applies regardless of differences in bar sizes.

For columns, the arrangement of bars at a lap splice is shown in Fig. 4. It should be noted that the amount of offset of the bars is greater for rectangular columns than for round columns. Column verticals to be lap spliced in square or rectangular columns, where column size does not change, are usually shop offset bent into the column above, unless otherwise shown by the A/E. The A/E shall indicate which vertical bars are to be offset bent for round columns in those cases where the column size doesn't change.

Where the depth of the footing, or footing and pedestal combined, is less than the minimum length of embedment required for dowels of a certain size, the size of dowel should be decreased and the number of dowels increased to give an equivalent area. This should also be shown on the structural drawings. Hooks at the ends of the bars can be desirable to

resist tension, but the hook may not be considered in determining the embedment provided for compression.

Separate splice bars (dowels) are necessary for splicing column bars where the column section changes 3 in. (80 mm) or more, where the placing of parts of the structure is delayed, or between various units of structures. Except for special cases, separate splice bars (dowels) should be the same number, size, and grade as the bars joined and should be of proper length to splice with the main bars, and shall be specified by the A/E.

Lap splices for deformed welded-wire fabric shall be shown by the A/E.* ACI 318 (318M) requires that, for deformed welded-wire fabric, the splice shall be at least 1.3 times the development length (8 in. [200 mm] minimum). The A/E shall indicate the required splice dimension(s).

Lap splices for plain welded-wire fabric shall also be shown by the A/E.* ACI 318 (318M) requires that the splice length, as measured between outermost cross wires of each fabric sheet, shall be not less than one spacing of cross wires plus 2 in. (50 mm) nor less than $1.5 \ell_d$ (6 in. [150 mm] minimum) when $A_s \text{ provided}/A_s \text{ required} < 2$. When $A_s \text{ provided}/A_s \text{ required} \geq 2$, only the requirement of $1.5 \ell_d$ (2 in. [50 mm] minimum) will apply. Therefore, the A/E can either show the required splice dimension or indicate a typical detail showing the lap splice length equal to one spacing of cross wires plus 2 in. (50 mm), if that controls.

2.7.4 Butt splices—Mechanical splices or welded splices can be specified or, for compression only, end-bearing splices can be specified as butt splices for vertical column bars. For No. 14 and 18 (No. 43 and 57) bars, butt splices shall be used. Special preparation of the ends of the vertical bars is usually required for butt splices. Where a mechanical splice is used, both ends of the bar can be either square cut, flame cut, or standard shear cut, depending on the type of splice used. Because mechanical splices are usually staggered between alternate vertical bars and their location depends on the design requirements, the A/E must indicate the types of mechanical splices permissible, their location, and end preparation required. Where bars are welded, the most common practice is to provide a square-cut end at the top of the lower bar and a double-beveled end on the bottom of the upper bar. Field preparation of ends by flame cutting is satisfactory. All welding of reinforcing bars shall conform to AWS D1.4.

2.8—Joint details

2.8.1 Rigid frame corners—The A/E shall exercise care in designing the corner joint of a rigid frame. All main reinforcing steel that passes through the joint shall be free of any kinks or discontinuous bending. The center of radius of the bend must be kept within the joint. This point is important in splicing the top bars from the girder to the outside bars in the column. The A/E must provide complete information, showing the radius of any nonstandard bends and location and dimensions of lap splices. If a mechanical or welded splice is to be used, a physical description must be provided. Tension in the

*Supplementary data on welded wire fabric appears in Chapter 2 ("Welded Wire Fabric") of the supporting reference data section.

concrete surrounding the reinforcing steel where the steel changes direction must be considered.

2.8.2 Wall intersections and corners—All horizontal wall reinforcing steel in one, or sometimes both, faces of a wall shall be sufficiently extended past a corner or intersection to be fully developed (Fig. 15 in Part C). The A/E shall indicate which, if any, horizontal reinforcing steel must be extended, how far it must be extended, and how it must be anchored at intersections and corners of walls and footings. In areas where the applicable building code requires earthquake-resistant design, standard practice requires adequate anchorage of all horizontal bars.

Walls with loads that open corner intersections must be reinforced differently than walls with loads that close such intersections. Typical details are shown in Fig. 15 for resistance against loads from outside or inside, with the reinforcing steel from the appropriate face or faces anchored. Precautions to restrain radial tension are similar to those for rigid frame corners.

2.8.3 Closed stirrups—Where the structural drawings show closed stirrups, these stirrups may be closed by two-piece stirrups using overlapping standard 90 degree end hooks enclosing a longitudinal bar, or by properly spliced pairs of U-stirrups or a standard one-piece Type T1 or T2 stirrup tie. At least one longitudinal bar must be located at each corner of the section, the size of this bar to be at least equal to the diameter of the stirrup but not less than a No. 4 (No. 13). These details shall be shown by the A/E. (see Fig. 12). It should be noted that the use of 90 degree hooks and lap splices in closed stirrups is not considered effective in situations where the member is subjected to high torsional stress. Tests (Reference 1) have shown premature failure caused by spalling of the concrete covering and consequent loss of anchorage in the 90 degree hooks and lap splices in these situations (see Fig. 16 in Part C).

2.8.4 Structural integrity—Specific details for continuity of reinforcing steel to meet structural integrity requirements shall be incorporated in the design details by the A/E. Continuity is required in cast-in-place construction for joists, beams, and two-way slabs. Continuity of selected flexural reinforcement is achieved by making bars continuous or providing Class A tension lap splices and terminating bars with standard hooks at noncontinuous supports. Certain proportions of top and bottom flexural reinforcement in perimeter beams shall be made continuous around the structure and confined with closed stirrups. See ACI 7.13 and Fig. 2 and 3, for example details for structural integrity.

2.9—Reinforcing steel supports

The A/E is responsible for specifying acceptable materials, and corrosion protection required for reinforcing steel supports, or both, and if required, for side form spacers, as well as the particular structural elements or areas in which each is to be used. Specifications for the use of reinforcing steel supports usually are based on established industry practice.* For more details on bar supports and side form spacers, see Chapter 5.

2.10—Special details for seismic design of frames, joints, walls, diaphragms, and two-way slabs

2.10.1 Introduction—In designs for high seismic risk (such as NEHRP Seismic Performance Categories D and E)[†] reinforced-concrete members shall satisfy ACI 318 (318M), Chapters 1 through 17 and Sections 21.2 through 21.7 of Chapter 21 to provide a structural system with adequate details to permit nonlinear response without critical loss of strength.

In designs for moderate seismic risk (such as NEHRP Seismic Performance Category C),[†] reinforced-concrete frames and two-way slabs shall satisfy ACI 318 (318M), Chapters 1 through 18 and Section 21.8 of Chapter 21.

The provisions of Chapters 1 through 18 of ACI 318 (318M) apply to the design and detailing of reinforced concrete structures in regions of low or no seismic risk (such as NEHRP Seismic Performance Categories A and B).[†]

For seismic design, member sizes should be selected and reinforcing steel arranged to avoid congestion of the reinforcement. Careful selection of member size and reinforcing steel arrangement will help to avoid difficulties in the placement of the reinforcement and concrete.

The requirements of Chapter 21 of ACI 318 (318M) are used to illustrate what the A/E shall convey to the detailer (and to familiarize the detailer with the seismic reinforcing steel details). Much information can be shown by schematic diagrams as shown in Fig. 5, 6, 7, 17 and 18 (in Part C). These special seismic details are, in principle, applicable to flexural frame members and frame members subjected to both bending and axial load in regions of high seismic risk.

It is important for the A/E to examine the reinforcing steel layouts carefully in three dimensions and give the detailer the proper information. This examination will show congestion at beam-column joints of beam, column, and hoop reinforcement. Large scale drawings, models, or mock-ups of the joint details, such as those shown in Fig. 7, may be worthwhile to ensure that a design can be assembled and concrete can be placed.

When subjected to reversals of lateral overloads, joints in frames and boundary members of walls must be capable of developing plastic hinging and continuing to resist loads after yielding of the reinforcing steel without crushing or brittle failure of the concrete. To develop this ductility, concrete in these members, including the joints, shall be confined by transverse reinforcement consisting of rectangular or circular hoops (see Fig. 5, 6, 7, 17, and 18).

2.10.2 Concrete—ACI 318 (318M) requires that the specified concrete strength f'_c shall not be less than 3000 psi (20 MPa). For lightweight aggregate concrete, f'_c shall not exceed 4000 psi (30 MPa).

*Established industry practices recommended for general use of bar supports issued by the Concrete Reinforcing Steel Institute are reprinted in the supporting reference data section.

[†]“NEHRP Recommended Provisions for the Development of Seismic Regulation for New Buildings” prepared by the Building Seismic Safety Council for the Federal Emergency Management Agency, issued in 1994, referred to as NEHRP. Seismic performance categories in ASCE 7 are similar to NEHRP. Regions of high earthquake risk correspond to Zones 3 and 4, regions of moderate earthquake risk to Zone 2, and low or no risk in Zone 1 in the Uniform Building Code.

2.10.3 Reinforcing steel—Longitudinal reinforcement, resisting earthquake-induced flexural and axial forces in frame members and in wall boundary members, shall comply with ASTM A 706/A 706M. ASTM A 615/A 615M Grade 60 and Grade 40 (420 and 300) can be used, provided that actual yield strength does not exceed the specified yield strength by more than 18,000 psi (120 MPa), and tensile strength is at least 25% greater than the actual yield strength.

In regions of moderate seismic risk, standard ASTM A615/A615M Grade 60 and 40 (420 and 300) can be used.

Test results indicate that welded-wire fabric hoops designed according to ACI 318 (318M) requirements are effective in confining the concrete in the joints (Reference 2).

2.10.4 Beams—High seismic risk*—At least two bars, top and bottom, shall be provided as continuous longitudinal reinforcement for beams. For beams framing into two opposite sides of a column, these bars shall extend through the column core at least twice the beam depth without splices (see Fig. 5) and shall develop the bars beyond their theoretical cut-off points.

At joint faces, the positive moment strength of the beam shall be equal to or greater than one-half the negative moment strength. At other locations in the beam, the positive and negative moment strengths shall be equal to or greater than one-fourth the negative moment strength at the face of either joint. The A/E shall indicate quantities of reinforcing steel, cut-off points, and length and location of splices to satisfy these multiple code requirements.

Continuous top bars must be spliced near the center of a span in frames where moments are usually minimum and gravity load moments do not usually produce tensile stresses. Bottom bars shall not be spliced at the columns because of possible reversal of beam stresses.

At beam-column joints, the A/E shall indicate where and how the bars, straight or hooked, are to be terminated.

Where beams frame into only one side of a column, as at exterior columns, top and bottom beam reinforcing steel must have a 90 degree hook that extends to the far face of the confined region (core) and bends into the joint.† The development length of the hook for tension shall not be less than $8d_b$, 6 in. (150 mm), or $f_y d_b / (65 \sqrt{f'_c})$ [$f_y d_b / (5.4 \sqrt{f'_c})$].

Hoops shall be provided in frame members over twice the member depth from the faces of the supports and toward midspan. If inelastic yielding can occur elsewhere, the A/E shall indicate location and hoop spacing requirements on both sides of the sections where the inelastic yielding can occur. Hoop spacing requirements are shown in Fig. 5.

Where hoops are not required by the A/E, stirrups shall be provided, spaced at not more than $d/2$ throughout the remaining length of the member and detailed as shown by the A/E.

2.10.5 Beams—Moderate seismic risk*—ACI 318 (318M) requires that, at joint faces, the positive moment strength of the beam shall be equal to or greater than one-third the negative moment strength. At other locations in the beam, the

positive and negative moment strengths shall be equal to or greater than one-fifth the negative moment strength at the face of either joint. The A/E shall indicate quantities of reinforcing steel required to satisfy ACI 318 (318M), cut-off points, and length and location of splices.

Stirrups shall be provided for a minimum length of twice the member depth from the support at an initial spacing of 2 in. (50 mm) and a remaining spacing not more than $d/4$, $8d_b$ of the smallest enclosed longitudinal bar, 24 diameters of the stirrup bar, or 12 in. (300 mm). For the remaining beam length, stirrups shall be spaced at not more than $d/2$.

2.10.6 Columns—High seismic risk‡—Transverse reinforcement consisting of single or overlapping rectangular hoops for rectangular columns, and single, circular hoops or spirals for round columns are required (see Fig. 6). A rectangular hoop is closed by overlapping 135 degree hooks having tail extensions of six bar diameters (3 in. [75 mm] minimum) inside the core of the hoop.

Crossties of the same bar size and spacing of hoops may be used, but each end of the crosstie shall engage a peripheral vertical bar. See Fig. 6 and 17.

Hoops at a maximum spacing not exceeding one-quarter of the minimum column dimension and 4 in. (100 mm) shall be provided within the joint and above and below the joint for a distance not less than the column depth, one-sixth the column clear height, and 18 in. (450 mm). ACI 318 (318M) provisions regulate the size and spacing of the hoops. Outside this region, hoops shall be as required for nonseismic columns, including requirements for shear, and spacing shall not exceed six times the diameter of the longitudinal column bars or 6 in. (150 mm).

Column verticals can be spliced by lap splices, mechanical splices, or welded splices. Lap splices are permitted only within the center half of the column length and shall be designed as tension splices. ACI 318 (318M) requires that mechanical splices or welded splices shall be staggered at least 24 in. (600 mm) and applied to alternate verticals. Offsets of longitudinal reinforcement is not recommended within the joint.

2.10.7 Columns—Moderate seismic risk‡—Tie spacing s_o over a length l_o from the face of the member shall not exceed the smaller of eight diameters of the smallest enclosed bar, 24 diameters of the tie bar, one-half the smallest cross-sectional column dimension, and 12 in. (300 mm). Length l_o shall not be less than one-sixth of the clear span (height) of the member, maximum cross-sectional dimension of the member, and 18 in. (450 mm). The first tie shall be spaced not more than $s_o/2$ from the joint face and the remaining ties shall be spaced not more than s_o .

2.10.8 Walls and diaphragms—High and moderate seismic risk—Walls and diaphragms, if designed as parts of the force-resisting system, are relatively stiff members compared with ductile beam-column frames. Because walls may or may not be designed as part of the primary lateral-load resisting system, it is most important that the A/E provide a complete description of the requirements for wall reinforcement. Usually

*A frame member is defined as a beam if the factored compressive axial load is not greater than $(A_g f'_c) / 10$.

†Core. This term is indirectly defined in ACI 10.0 by the term “ A_c ” (area of core) = area within outside dimension of the confining reinforcement.

‡A frame member is defined as a beam if the factored compressive axial load is greater than $(A_g f'_c) / 10$.

this task can be accomplished by identifying structural walls and diaphragms and reference to typical details (see Fig. 18).

The vertical and horizontal reinforcement shall be placed in at least two curtains if the in-plane factored shear force exceeds $2A_{cv}\sqrt{f'_c}$ [$(1/6)A_{cv}\sqrt{f'_c}$]. The reinforcement ratio in each direction shall be equal to or greater than 0.0025 with a maximum bar spacing of 18 in. (450 mm).

When the compressive force in a boundary member exceeds $0.2f'_cA_g$, the member shall be reinforced as a column in a high seismic risk area with closely spaced hoops extending until the compressive force is less than $0.15f'_cA_g$. Transverse reinforcement from wall and diaphragm members shall be fully developed within the confined cores of boundary members.

2.10.9 Joints—High seismic risk frames—Forces in longitudinal beam reinforcing steel at joint faces shall be based on a flexural tension stress of $1.25f_y$ and a corresponding increase in balancing compressive stresses and shear. Transverse hoop reinforcement, as for high-risk seismic columns, shall be provided in the joints. If the joint is confined by structural members meeting special requirements, lesser amounts of transverse reinforcement can be used. The A/E shall evaluate requirements for confinement and end anchorage of longitudinal beam reinforcement. These requirements can often be shown by typical details (see Fig. 5, 6, 7, and 17).

2.10.10 Two-way slabs without beams—Moderate seismic risk—Reinforcing steel for the fraction of M_u to be transferred by moment (Eq. (13-1), ACI 318 [318M]), but not less than half the total reinforcement required for the column strip, shall be placed in the width of slab between lines 1.5 times slab or drop panel thickness on opposite faces of the column. (This width equals $3h + c_2$ for edge and interior columns or $1.5h + c_2$ for corner columns.) The A/E shall show the reinforcing steel to be concentrated in this critical width. See Fig. 19(d) in Part C for typical detail used for locating other bars in nonseismic areas.*

A minimum of one-fourth of the column strip top reinforcing steel shall be continuous throughout the span.

Continuous column strip bottom reinforcing steel shall be not less than one-third of the total column strip top reinforcement at the support. A minimum of one-half of all bottom reinforcement at midspan shall be continuous and developed at the faces of the supports.

All top and bottom reinforcing steel shall be developed at discontinuous edges.

2.11—Corrosion-resistant coatings for reinforcing steel

2.11.1 General

2.11.1.1 Specification—Coated reinforcing steel provides a corrosion-protection system for reinforced-concrete structures. Structural drawings for structures or elements of structures that contain coated reinforcing steel shall include all of the essential information noted previously for uncoated reinforcement. The A/E must be cognizant that coated reinforcing steel undergoes further processing as compared with

uncoated reinforcement. The coating process adds time to the normal delivery cycle. Replacement reinforcing steel or additional reinforcement to correct oversights may not be readily available. Therefore, it is important that the A/E convey specific complete instructions in the project specifications or on the structural drawings for the use of coated reinforcing steel.

2.11.1.2 Provisions to be included in project specifications—Provisions to be included are:

1. *Mechanical splices*—Specify requirements for repair of damaged coating after installation of mechanical splices.

2. *Welded splices*—Specify any desired or more stringent requirements for preparation or welding, such as removal of coating, beyond those contained in AWS D1.4; specify requirements for repair of damaged coating after completion of welding.

3. *Field bending of coated bars partially embedded in concrete*—If permitted by the A/E, specify requirements for repair of damaged coating after completion of bending operations.

4. *Cutting of coated bars in the field*—This practice is not recommended, but if required and permitted by the A/E, specify requirements for coating the ends of the bars.

5. *Limits on coating damage*—Specify limits on permissible coating damage caused by handling, shipment, and placing operations, and when required, the repair of damaged coating.

2.11.1.3 Usage—For overall economy, maximize the use of straight bars and use the fewest possible different bar sizes for a project. On projects where uncoated and coated bars are used, to avoid confusion, be precise in identifying those bars that are to be coated. It is seldom sufficient to call for coated reinforcing bars in an element with a general note. Reinforcing bars projecting into the element must be identified if they are to be coated.

2.11.2 Epoxy-coated reinforcing bars

2.11.2.1 Material specification—See “Standard Specification for Epoxy-Coated Reinforcing Steel Bars” (ASTM A 775/A 775M). To meet ACI 318 (318M), the reinforcing bars that are to be epoxy-coated shall conform to the requirements of ACI 3.5.3.1.

2.11.2.2 Identification—Epoxy-coated bars are identified with a suffix (E), or with an asterisk (*) and a note stating that all bars marked are to be epoxy-coated.

2.11.2.3 Compatible tie wire and bar supports—Coated tie wire or other acceptable materials must be specified for fastening epoxy-coated reinforcing bars. Suitable coatings are nylon, epoxy, or vinyl. Bar supports should be made of dielectric material or wire bar supports should be coated with dielectric material, such as epoxy or vinyl compatible with concrete, for a minimum distance of 2 in. (50 mm) from the point of contact with the epoxy-coated reinforcing bars. Reinforcing bars used as support bars should be epoxy-coated.

2.11.3 Zinc-coated (galvanized) reinforcing bars

2.11.3.1 Material specification—See “Standard Specification for Zinc-Coated (Galvanized) Steel Bars For Concrete Reinforcement” (ASTM A 767/A 767M). To meet ACI 318

*Even more necessary for moderate seismic risk, wind, or other lateral load.

(318M) requirements, the reinforcing bars that are to be zinc-coated (galvanized) shall conform to ACI 3.5.3.1.

2.11.3.2 Supplementary requirements—There are three Supplementary Requirements in ASTM A 767/A 767M: Supplementary Requirement S1 requires sheared ends to be coated with a zinc-rich formulation; when bars are fabricated after galvanizing, S2 requires damaged coating to be repaired with a zinc-rich formulation; and if ASTM A 615/A 615M billet-steel bars are being supplied, S3 requires that a silicon analysis of each heat of steel be provided. S1 and S2 should be specified when fabrication after galvanization includes cutting and bending. S2 should be specified when fabrication after galvanization includes only bending.

2.11.3.3 Coating weights (mass)—Table 1 of ASTM A 767 has two classes of coating weights (mass). Class 1 (3.5 oz/ft² [1070 g/m²]) is normally specified for general construction.

2.11.3.4 Other embedded metals—No uncoated reinforcing steel, nor any other embedded metal dissimilar to zinc, should be permitted in close proximity to galvanized reinforcing bars except as part of a cathodic protection system.

2.11.3.5 Identification—Bars are usually galvanized after fabrication. Bars that require special finished bend diameters (usually smaller bar sizes for stirrups and ties) should be identified. Maintenance of identification to the point of shipment during the galvanizing process is the responsibility of the galvanizer. Regular tags plus metal tags should be attached to each bar bundle. (The regular tag is often consumed in the galvanizing process, leaving the metal tag for permanent identification.) Zinc-coated (galvanized) bars are identified with a suffix (G) and a note stating that all bars marked as such are to be zinc-coated (galvanized).

2.11.3.6 Compatible tie wire and bar supports—No dissimilar metals nor uncoated bars should be permitted in the same reinforced-concrete element with galvanized bars. Galvanized bars must not be coupled to uncoated bars. Zinc-coated tie wire or nonmetallic coated tie wire should be used. Wire bar supports and support bars should be galvanized or coated with dielectric material, or bar supports should be made of dielectric material.

PART B—RESPONSIBILITIES OF THE DETAILER

CHAPTER 3—PLACING DRAWINGS

3.1—Definition

Placing drawings are working drawings that show the number, size, length, and location of the reinforcing steel necessary for the placement and fabrication of the material. Placing drawings can comprise plans, details, elevations, schedules, material lists, and bending details. They can be prepared manually or by computer.

3.2—Scope

Placing drawings are intended to convey the A/E's intent as covered in the contract documents. The contract documents plus any additions, such as addenda issued by the A/E (per terms agreed on in the contract if issued after the contract is made), constitute the sole authority for information in placing drawings. The placing drawings must include all infor-

mation necessary for complete fabrication and placing of all reinforcing steel.

3.3—Procedure

Placing drawings are prepared by a detailer in accordance with the A/E's instructions contained in the contract documents. Any necessary, additional information must be supplied by the contractor concerning field conditions, field measurements, construction joints, and sequence of placing concrete. After approval by the A/E, including necessary revisions, the drawings may be used by the fabricator and placer.

3.4—Drawing standards

Placing drawings are prepared according to the same general standards as structural drawings.

3.4.1 Layout—Drawings usually show a plan, elevations, sections, and details of a structure, accompanied by schedules for footings, columns, beams, and slabs. The plan normally is drawn in the upper left corner of the sheet, with the elevations and details below and to the right of the plan. Schedules (and bending details) are normally placed in the upper right corner of the drawing. A figure in the supporting reference data section presents a recommended layout.

An arrow indicating the direction of North should be placed beside every plan view.

3.4.2 Symbols and notation—Common symbols and abbreviations for placing drawings are shown in the supporting reference data section.

Where unusual details or conditions require use of other (special) symbols or abbreviations, the drawings must provide explanations of the notation applied.

3.4.3 Schedules—The reinforcing steel of floors and many other parts of structures can best be shown in tabular form commonly referred to as a schedule. A schedule is a compact summary of all the bars complete with the number of pieces, shape and size, lengths, marks, grades, coating information, and bending details from which bar lists can be written easily and readily. Although these schedules usually include the bending details for bent bars, separate bending detail schedules can be used.

3.4.4 Coated reinforcing bars—When coated reinforcing bars are detailed along with uncoated reinforcing bars, the coated reinforcing bars must be identified in some manner, such as with a suffix (E) or (G) or with an asterisk (*), and a note stating that all reinforcing bars marked as such are to be epoxy-coated or galvanized. Epoxy-coated reinforcing bars listed with uncoated reinforcing bars in schedules or bills of materials must also be marked with (E) or (*). The designation (G) is appropriate for galvanized reinforcing bars.

3.5—Building drawings

Placing drawings, ordinarily prepared by the fabricator, show details for fabrication and for the placing of reinforcing steel. They are not for use in constructing formwork (except joist forms when these are supplied by the same fabricator), and consequently the only required dimensions are those necessary for the proper location of the reinforcing steel. Building dimensions are shown on the placing drawing only if

necessary to locate reinforcing steel properly, as the detailer becomes responsible for accuracy of dimensions, when given. The placing drawings must be used with the structural drawings.

Bending details can be shown on a separate drawing instead of on the placing drawings.

3.5.1 General requirements—On receipt of the structural drawings, the fabricator takes the following steps:

1. Prepares placing drawings (including bending details);
2. Submits placing drawings, if required by the project specifications, to the specified authority for review and approval;
3. Prepares bar lists (bills of materials);
4. Fabricates reinforcing steel;
5. Provides coated bars if specified;
6. Provides bar supports per customer requirements; and
7. Tags, bundles, and delivers the fabricated reinforcing bars to the job site.

It should be noted that the general term fabricator, as used in this document, refers to a company that employs detailers, estimators, and shop personnel. In this regard, it is actually the detailer who performs steps 1, 2, and 3, whereas the shop personnel do steps 4, 5, 6, and 7.

Placing drawings must show the size, shape, grade, and location of coated and uncoated bars in the structure, including bar supports, if supplied by the fabricator. They also serve as the basis for preparing bar lists.

Where approval of placing drawings is required, the placing drawings should be submitted before reinforcing bar fabrication is begun.

For the convenience of both the contractor and fabricator, reinforcing steel is detailed, fabricated, and delivered by units, which generally consist of building components, such as footings, walls, columns, each floor, and roof. A separate placing drawing and bar list are usually made for each component. For small structures, all reinforcing steel can be handled as one unit. For large projects, the contractor may desire a unit, such as a single floor, to be divided to correspond with the construction schedule. Such arrangements, between the contractor and fabricator, with the A/E's approval, are made before the detailing is begun. All sections should be kept as large as practical because it is more economical to detail and fabricate for large units, especially where there is apt to be a duplication of bars.

3.5.2 Marks—Slabs, joists, beams, girders, and sometimes footings that are alike on structural drawings are given the same designation mark. Where possible, the same designations should be used on the placing drawings as on the structural drawings. When members alike on the structural drawings are slightly different on the placing drawings, a suffix letter is added to the designation to differentiate the numbers. If some of the beams marked 2B3 on the structural drawing actually differ from the others, the placing drawing would show some of the beams as 2B3 and the others as 2B3A. In reinforced-concrete joist floors, there can be so many variations from the basic joists shown on the structural drawings that it is necessary to change the basic designations (for example, from prefix J to prefix R, for rib).

Columns, and generally footings, are numbered consecutively or are designated by a system of coordinates on the structural drawings. The same designations should be used on placing drawings.

The described marking systems identify individual, reinforced-concrete members of a structure. Reinforcing bars must be individually identified on placing drawings. Only bent bars are given a mark to assist the placer in selecting the proper bars for each member. The straight bar size and length is its own identification.

3.5.3 Schedules—Reinforcing steel in elements of a structure can be drawn on placing drawings either on the plan, elevation, or section, or can be listed in a schedule. It is acceptable practice to detail footings, columns, beams, and slabs in schedules. There is no standard format for schedules. They take the place of a drawing, such as a beam elevation, and must clearly indicate to the placer exactly where and how all the material listed is to be placed.

3.5.4 Responsibility of the detailer—The responsibility of the detailer in preparing a placing drawing is to carry out all instructions on the contract documents.

The A/E must furnish a clear statement of the requirements. The detailer must carry out the requirements supplied by the A/E. The A/E, in either the project specifications or structural drawings, may not refer the detailer to an applicable building code for information to use in preparing placing drawings. This information must be interpreted by the A/E and must be shown in the form of specific design details or notes for the detailer to follow.

3.5.5 Beams and joists—For beams, joists, and girders, reinforcing steel is usually shown in schedules. Bending details may be separate or incorporated in the schedule. The detailer must show number, mark, and size of members; number, size, and length of straight bars; number, size, mark, and length of bent bars and stirrups; spacing of stirrups; offsets of bars; lap splices; bar supports; and any other special information necessary for the proper fabrication and placement of the reinforcing steel.

Among the special items that must be noted are:

1. Overall length of bar;
2. Height of hook where such dimensions are controlling;
3. Lap splice lengths;
4. Offset dimensions, if any; and
5. Location of bar with respect to supporting members where the bar is not dimensioned symmetrically on each side of the support.

3.5.6 Slabs—Reinforcing steel for slabs can be shown in plan views, in a schedule, and sometimes even in section. The schedule and bending details for slabs are similar to those for beams.

Panels that are exactly alike are given an identifying letter and reinforcing steel is shown for only one panel of each kind. In skewed panels, such as for the quadrant of a circle, the bars are fanned out so that they are placed at the required spacing at a specific location, usually at the midspan. Additional bars around openings, if required, must be shown.

3.5.7 Columns—Placing drawings for columns generally use a schedule form for detailing. The detailer must not only

interpret the structural drawing, but clearly convey this interpretation to the placer. The detailer must show the quantity, size, and length or mark of all bars, including dowels, principal vertical bars, and ties. The detailer must also include plan sketches of typical bar arrangements for all but the simplest conditions. The detailer must clearly show length and location of lap splices, location of mechanical splices or welded splices, and position of offset bars.

3.5.8 Dowels—Dowels should be detailed, preferably, with the reinforcing steel in the element that is placed first. They must be ordered with the element to be available for placement at the proper time.

3.5.9 Reinforcing steel supports—Reinforcing steel supports specified in the contract documents, including quantities and description, can be shown on the placing drawings.

Bar support placing layouts for typical panels are required for two-way reinforcing steel and wherever needed to clarify placing sequence or quantities required. These layouts can be shown on the placing drawing or given by reference to the *CRSI Manual of Standard Practice*. Support bars, when required, must be shown clearly and identified on the placing drawings.

3.6—Highway drawings

Unlike the customary practice in the field of reinforced-concrete buildings, many state highway departments prepare a combination structural and placing drawing. The combination drawing includes a list of reinforcing steel materials from which the fabricator prepares bar lists. The placer uses the combination drawing to place the reinforcing bars. Highway departments that do not use combination drawings follow the procedures of [Section 3.5](#).

3.6.1 Marks—Usually, each highway structure is identified by a bridge number, street name, or a station number (each station being 100 linear ft [30 m]) that designates its location on the project. This station identification or bridge number must be shown on all bundle tags and shipping papers to facilitate proper distribution of reinforcing bars on delivery.

For small, simple structures such as culverts, slab bridges, manholes, and catch basins, a station number in addition to the title description of the structure is sufficient identification without dividing the structure into smaller units by further marking.

Larger structures, such as reinforced-concrete deck girders, I-beam bridges, continuous-type bridges, and arches, consist of small units that together make up a complete structure. These units are referred to as end bents, intermediate bents, abutments, piers, retaining walls, end spans, intermediate spans, etc., and must be designated by markings. The construction units of unusually long culverts with more than one design of barrel, for varying load conditions or, where construction joints are required across the barrel, can be identified by section numbers. Schedules of reinforcing bars are used to divide a structure into parts enabling the fabricator to make it more convenient for the placer by delivering the bars in lots as required.

For highway structures, both straight and bent bars are given an individual mark. In highway structures, such as culverts and bridge spans, the arrangement of bars is the same, re-

gardless of size or length. Standardized marks are sometimes used for bars occurring in the same relative position in culverts.

Any system of letters and numerals is acceptable. Some A/E's not only provide individual bar markings, but also indicate, by the mark, where the bar is placed in the structure.

3.6.2 Schedules—Highway structural drawings most often show details of the various elements directly on the plan or elevation. Schedules are sometimes used for piers, small structures, and even retaining walls. Highway structural drawings usually include, when detailed completely, a type of schedule that is really a bill of material, sometimes segregated by elements of a structure. These drawings are used by the fabricator to prepare shop bar lists.

3.6.3 Dimensions—When the drawings for highway structures are a combination of structural and placing drawings from which the structure will be built, all dimensions must be shown clearly. The contractor should not have to compute any needed dimensions. Drawings must show the dimensions of concrete protection for all reinforcing steel. For example, they must plainly show whether the cover dimension specified on a girder is the clear distance from the main reinforcing steel or the clear distance from the stirrups. Where separate placing drawings are prepared, structural dimensions may be omitted following the same practice as for buildings.

3.6.4 Reinforcing steel—Drawings must show the grade, size, spacing, splices, and location of the coated and uncoated bars in the structure. The bar schedule (combined drawing) must show the number of pieces, size, length, mark of bars, and bending details of all bent bars.

Reinforcing steel for larger structures is usually detailed, fabricated, and delivered by units for the convenience of both the contractor and fabricator; for example, footings, abutments, piers, and girders. The bar list is then similarly subdivided. If the structure is sufficiently large, a separate drawing and bar list is made for each unit.

Reinforcing bars for foundations, piers, abutments, wing walls, and slabs are usually shown on plan, section, or elevation views. Reinforcing steel can be shown in the simplest and clearest manner, however, the bar list must be a complete summary.

To be certain that all of the reinforcing steel is properly placed or positioned in a unit, a cross section is frequently required in addition to the plan and elevation of the unit where the bars are shown.

3.6.5 Reinforcing steel supports—Plain metal supports are used widely as a means of securely holding reinforcing steel in proper position while the concrete is being placed. Plastic coated or stainless legs can be specified to avoid possible rusting at points of exposure. Precast concrete blocks are used in some states, particularly in the western United States. Other types of proprietary supports are available and may be suitable. Support bars, when furnished, should be shown clearly and identified.

Where an exposed concrete surface is to receive special finishing treatments, such as sandblasting, bush-hammering, or any other removal of surface mortar, special consideration

must be given to such things as selecting bottom bar supports and side form spacers that will not rust or otherwise impair the finished surface appearance.

Class of wire bar support, precast concrete blocks, or other proprietary supports, and locations where each is to be employed, should be specified or shown in the contract documents. The detailer should identify the specified types and show locations where each is to be used.

3.7—Detailing to fabricating standards

It is standard practice in the industry to show all bar dimensions as out-to-out and consider the bar lengths as the sum of all detailed dimensions, including Hooks A and G (see Table 1).

3.7.1 Bending—To avoid creating excessive stresses during bending, bars must not be bent too sharply. Controls are established by specifying the minimum inside radius or inside diameter of bend that can be made for each size of bar. The radius or diameter of the bend is usually expressed as a multiple of the nominal diameter of the bar d_b . The ratio of diameter of bend to diameter of bar is not a constant because it has been found by experience that this ratio must be larger as the bar size increases.

The minimum diameters of bend specified by ACI 318 (318M) for reinforcing bars, measured on the inside of the bar, are:

Bar sizes, No.	Other than ties/stirrups	Ties or stirrups
3, 4, 5 (10, 13, 16)	$6d_b$	$4d_b$
6, 7, 8 (19, 22, 25)	$6d_b$	$6d_b$
9, 10, 11 (29, 32, 36)	$8d_b$	—
14, 18 (43, 57)	$10d_b$	—

The inside diameter of bends of welded-wire fabric (plain or deformed) for stirrups and ties, as specified by ACI 318 (318M), shall not be less than $4d_b$ for deformed wire larger than D6 (MD38.7) and $2d_b$ for all other wires. Bends with inside diameter of less than $8d_b$ shall not be less than $4d_b$ from the nearest welded intersection.

3.7.2 Hooks—ACI 318 (318M), Section 7.2 specifies minimum bend diameters for reinforcing bars. It also defines standard hook (Section 7.1) to mean the following:

- a) A 180 degree bend plus an extension of at least $4d_b$, but not less than 2-1/2 in. (60 mm), at the free end of the bar; or
- b) A 90 degree bend plus an extension of at least $12d_b$ at the free end of the bar; or
- c) For stirrup and tie hooks only, either a 90 degree bend plus $6d_b$ extension for No. 3, 4, 5 (No. 10, 13, 16), and $12d_b$ extension for No. 6, 7, and 8 (No. 19, 22, and 25), or a 135 degree bend plus an extension of at least $6d_b$ at the free end of the bar. For closed ties, defined as hoops in Chapter 21 of ACI 318 (318M), a 135 degree bend plus an extension of at least $6d_b$ but not less than 3 in. (75 mm).

The minimum bend diameter of hooks shall meet the foregoing provisions. The standard hooks (Table 1) were developed such that the minimum requirements were met, but at the same time the need to allow for springback in fabrication and maintaining a policy of production fabrication pin size no smaller than the ASTM A615/A615M bend test pin size was recognized as well. In the Table, the extra length of bar allowed for the hook is designated as A or G and shown to the nearest 1 in. (25 mm) for end hooks and to the nearest 1/4 in. (5 mm) for stirrup and tie hooks.

Where the physical conditions of the job are such that either J, A, G, or H of the hook is a controlling dimension, it must be so noted on the drawings, schedules, and bar lists.

3.7.3 Stirrup anchorage

3.7.3.1 There are several permissible methods for stirrup anchorage. The most common is to use one of the hooks shown in Table 1. Types S1 to S6 in Fig. 10 illustrate not only the uses of the two types of hooks, but also the directions in which the hooks can be turned. In detailing the anchorage, care must be taken that the ends of stirrup hooks that are turned outward into shallow slabs have adequate cover. If not, the hooks should be turned inward and this change brought to the A/E's attention.

3.7.3.2 Where the free ends of stirrups cannot be tied to longitudinal bars, or where there are no longitudinal bars, stirrup support bars should be specified by the A/E.*

3.7.4 Standard bar bends

3.7.4.1 To list the various types of bent bars in a schedule, it is necessary to have diagrams of the bars with the lengths of the portions of the bars designated by letters. A chart of such standard bar bends is shown in Fig. 10.

3.7.4.2 Dimensions given for Hooks A and G are the additional length of bar allowed for the hook as shown in Table 1. For straight portions of the bar, the distance is measured to the theoretical intersection of the outside edge line extended to the outside edge line of the adjacent straight portion, or to the point of tangency to a curve, from which point the length of the latter is tabulated, as in Types 10 and 11 in Fig. 10. Truss bar dimensioning is special and is shown in large-scale detail in Fig. 10.

3.7.5 Radius bending—When reinforcing bars are used around curved surfaces, such as domes or tanks, and no special requirement is established in the contract documents, bars prefabricated to a radius equal or less than those in the following table are prefabricated by the reinforcing bar fabricator. In the smaller sizes, the bars are sprung to fit varying job conditions, such as location of splices, vertical bars, jack rods, window openings, and other blocked out areas in the forms. The larger size bars, which are more difficult to spring into desired position, are ordinarily employed in massive structures where placing tolerances are correspondingly larger.

*These decisions should be shown on the structural drawings. If not, the detailer may suggest solutions, but only when subject to review and approval by the A/E. The final decision on these design problems is the A/E's responsibility.

When radial prefabrication is required

Bars are to be prefabricated when either radius or bar length is less than tabulated value

Bar size, No.	Radius, ft (mm)	Bar length, ft (mm)
3 (10)	5 (1500)	10 (3000)
4 (13)	10 (3000)	10 (3000)
5 (16)	15 (4500)	10 (3000)
6 (19)	40 (12,000)	10 (3000)
7 (22)	40 (12,000)	10 (3000)
8 (25)	60 (18,000)	30 (9000)
9 (29)	90 (27,000)	30 (9000)
10 (32)	110 (33,000)	30 (9000)
11 (36)	110 (33,000)	60 (18,000)
14 (43)	180 (54,000)	60 (18,000)
18 (57)	300 (90,000)	60 (18,000)

Radially prefabricated bars of any size tend to relax the radius originally prefabricated as a result of time and normal handling. The last few feet involved in the lap splice area often appear as a tangent rather than a pure arc, due to limitations of standard bending equipment. For these reasons, final adjustments are a field placing problem to suit conditions and tolerance requirements of a particular job. See Fig. 8 and 9 for radial tolerances and Section 4.2(c)3. Bars requiring a larger radius or length than shown in the table are sprung in the field without prefabrication.

The presence of the tangent end does not create any problem on bar sizes No. 3 through 11 (No. 10 through 36) as they are generally lap spliced and tangent ends are acceptable. No. 14 and 18 (No. 43 and 57) bars cannot be lap spliced, however, and are usually spliced using a proprietary mechanical splice or a butt weld. It is a problem to place a radially bent bar when using a mechanical splice sleeve because of the tangent ends on bars bent to small radii. To avoid this problem, all No. 14 and 18 (No. 43 and 57) bars bent to a radius of 20 ft (6000 mm) or less should be furnished with an additional 18 in. (450 mm) added to each end. This 18 in. (450 mm) tangent end is to be removed in the field by flame cutting. Bars bent to radii greater than 20 ft (6000 mm) will be furnished to the detailed length with no consideration given to the tangent end. The ends of these bars generally are saw cut.

Shop removal of tangent ends can be made by special arrangement with the reinforcing bar supplier.

3.7.6 Slants—To determine the length of the straight bar necessary to form a truss bar, the length of the slant portion of the bar must be known. The standard angle is 45 degrees for truss bars, with any other angles being special. Slants and increments are calculated to the closest 1/2 in. (10 mm) so that for truss bars with two slants, the total increment will be in full inches (25 mm). This makes the computation easier and is within the tolerances permitted. It is important to note that when the height of the truss is too small, 45 degree bends become impossible. This condition requires bending at a lesser angle and lengthens the slant portion.

3.7.7 Column verticals

3.7.7.1 General—The A/E shall indicate the grade of reinforcing steel required on the structural drawings or in the project specifications. The detailer shall show special specification requirements for grade in listing column verticals for each story. In multistory columns, lower stories are sometimes designed for higher strength grades. Special requirements for bars to be butt-spliced can also be included.

A table in the supporting reference data section shows the number of bars that can be placed within spiral reinforcement in conformance with ACI 318 (318M). Three splice arrangements are shown: butt-splices, radially lapped splices with verticals or dowels from below inside of bars above, and circumferentially lapped splices with dowels from below the bars above. Spacing for the latter also applies to butt-spliced two-bar bundles.

Maximum number of bars for the two lap splice arrangements assumes all bars are spliced at the same cross section. For the butt-splice arrangement, no allowance was included for increase in diameter at couplers or end-bearing devices, or for access to butt weld.

3.7.7.2 Offset between column faces—Where a column is smaller than the one below, vertical bars from below must be offset to come within the column above, or separate dowels must be used. The slope of the inclined portion shall not exceed 1 to 6. In detailing offset column bars, a bar diameter plus clearance must be added to the desired offset. In the corners of columns, bars are usually offset on the diagonal, which requires that the offset be increased accordingly.

For any offset between column faces less than 3 in. (80 mm), the vertical bar should be offset bent. When the offset is 3 in. (80 mm) or more, the vertical bars in the column below should be terminated at the floor slab and separate straight dowels provided.

3.7.7.3 Lap splices—Typical arrangement of bars at a lap splice is shown in Fig. 4. Unless special details are provided on the structural drawings, all column verticals to be lap spliced in square or rectangular columns must be shop offset bent into the column above except as noted in Section 3.7.7.2. General practice is to use the offset for the corner bars that must be bent diagonally as the typical offset dimension for all the bars in the column. Column verticals in round columns where column sizes do not change must be offset bent only if a maximum number of lap spliced bars is desired in the column above (see table in the supporting reference data section).

3.7.8 Column spirals

3.7.8.1 General—Spirals shall be provided with 1-1/2 extra turns at both top and bottom. The height (or length) of a spiral is defined as the distance out-to-out of coils, including the finishing turns top and bottom, with a tolerance of plus or minus 1-1/2 in. (40 mm). Where a spiral cannot be furnished in one piece, it may be furnished in two or more sections to be field welded, or with additional length at each of the ends of each section to be lapped in the field, 48 diameters minimum, but not less than 12 in. (300 mm). The sections must be identified properly by mark numbers to ensure proper assembly.

Spacers are sometimes used for maintaining the proper pitch and alignment of the spiral and, when used, must conform to the minimum requirements of a table in the supporting reference data section. Maximum length of spacers is that of the spiral plus one pitch. One alternative method to using spacers is to ship the spiral as a compressed coil and tie it in place in the field. The project specifications or subcontract agreements should be written clearly to cover the supply of spacers or field tying of the spiral reinforcement.

The height of one-piece assembled spirals for fabrication and shipping is limited to 25 ft (7500 mm) unless special handling arrangements are made. For greater heights, spirals must be field spliced by lapping or welding. Spacers can be provided. Spirals are also used in piles, but these do not fall within ACI 318 (318M) definition of a spiral and are usually made of light wire and relatively large pitch.

3.7.8.2 Spiral details—Unless otherwise specifically provided, spirals should be detailed as extending from the floor level or top of footing or pedestal to the level of the lowest horizontal reinforcement in the slab, drop panel, or beam above. In a column with a capital, the spiral shall extend to the plane at which the diameter or width of the capital is twice that of the column. See [Detail 2, Fig. 4](#). If the structural drawings require lateral reinforcement in the column between the top of the main spiral and the floor level above, it should be provided by a stub spiral (short section of spiral) or by circular column ties. Where stub spirals are used, they must be attached to the main spiral for shipment or fully identified by mark numbers.

3.7.9 Dowels—Dowels will be provided by the detailer as specified in the contract documents for the following:

1. Column footings to columns;
2. Wall footings to walls;
3. Wall intersections;
4. Stairs to walls;
5. Construction joints in footings, walls, and slabs;
6. Columns at floor levels where the vertical reinforcement cannot be offset bent and extended; and
7. Other places where it is not possible or desirable to extend the reinforcing steel continuously through a joint.

Dowels, preferably, should be detailed with that portion of the structure where concrete is placed first. They should always be ordered with that portion.

3.7.10 Bar lists—Bar lists used in cutting, bending, tagging, shipping, and invoicing are prepared from placing drawings. Bars are grouped separately on the bar list as follows:

1. Straight;
2. Bent, including stirrups and ties; and
3. Spirals.

The grade of reinforcing steel for all items must be shown.

Straight bars are usually grouped according to size, with the largest size first and those of the same size listed in the order of their length with the longest bar first.

Bent bars, stirrups, and ties are usually listed in a similar manner.

Spirals may be subdivided and listed in groups by the size of bar, diameter of spiral, pitch of spiral, and length. See the bar list example in the supporting reference data section.

CHAPTER 4—FABRICATING PRACTICE STANDARDS

4.1—Fabrication

A fabricated reinforcing bar is any deformed or plain steel bar for concrete reinforcing steel, conforming to ASTM specifications A 615/A 615M, A 616/A 616M, A 617/A 617M, or A 706/A 706M, which is cut to a specified length or cut and bent to a specified length and configuration. Welded-plain- and deformed-wire fabric meeting ASTM A 185 or A 497, respectively, and spirals formed from cold drawn wire conforming to ASTM A 82 or A 496, are also considered concrete reinforcement within this definition. Other materials used as concrete reinforcement and processes other than cutting and bending are not included in this definition.

4.2—Extras

Reinforcing bars are sold on the basis of their theoretical weights (mass) computed from the values given in the ASTM specifications, as calculated from the detailed placing drawings, lists, or purchase orders. In determining the weight (mass) of a bent bar, it is standard practice in the industry to show all bar dimensions as out-to-out and consider the bar lengths required for fabrication as the sum of all detailed dimensions, including Hooks A and G (see [Fig. 10](#)).

Charges for extras can be added to the base price per hundredweight. In this event, the principal extra charges are:

- a) Size extras—vary as bar size changes;
- b) Grade extras—are added to some grades of bars; and
- c) Bending extras—are added for all shop bending.

Bending extra charges are separated into three classes as follows:

1. Light bending—All No. 3 (No. 10) bars, stirrups, hoops, supplementary ties, and ties, and all bars No. 4 through 18 (No. 13 through 57) that are bent at more than six points in one plane, or bars that are bent in more than one plane (unless special bending, see below), all one-plane radius bending with more than one radius in any bar (three maximum), or a combination of radius and other type bending in one plane (radius bending being defined as all bends having a radius of 12 in. [300 mm] or more to inside of bar);
2. Heavy bending—Bar sizes No. 4 through 18 (No. 13 through 57) that are bent at not more than six points in one plane (unless classified as light bending or special bending) and single radius bending; and
3. Special bending—All bending to special tolerances (tolerances closer than those shown in [Fig. 8](#) and [9](#)), all radius bending in more than one plane, all multiple plane bending containing one or more radius bends, and all bending for precast units.

d) Services and special fabrication—Extra charges for services and special fabrication may be computed individually to suit conditions for each product on items such as:

1. Detailing, listing, or both;

2. Owner's quality assurance/control requirements;
3. Transportation;
4. Epoxy coating and galvanizing;
5. Painting, dipping, or coating;
6. Spirals and continuous hoops;
7. Shearing to special tolerances;
8. Square (saw-cut) ends;
9. Beveled ends or ends not otherwise defined;
10. Bar threading;
11. Special bundling and tagging;
12. Overlength bars, and overwidth bars, or both; and
13. Welding.

4.3—Tolerances

There are established, standard industry fabricating tolerances that apply unless otherwise shown in the project specifications or structural drawings. Fig. 8 and 9 define these tolerances for the standard bar bends shown in Fig. 10. Note that tolerances more restrictive than these may be subject to an extra charge. For further tolerance information, see ACI 117.

CHAPTER 5—SUPPORTS FOR REINFORCING STEEL

5.1—General

The contract documents usually outline the need and requirements for reinforcing steel supports. The following requirements are applicable to supports for reinforcing bars, and may be applicable to supports for wire or welded-wire fabric.

5.1.1 General requirements—When the contract documents specify merely that reinforcing steel “shall be accurately placed and adequately supported before the concrete is placed, and shall be secured against displacement within permitted tolerances,” the contractor is free to select and purchase the type and class of wire bar supports, precast block, or other materials for each area.

5.1.2 Specific requirements—When the contract documents specify types or material for bar supports in different areas, the detailer for the supplier must indicate these materials and areas in which they are to be used, number, size, type, arrangement, and quantities required. These details must be outlined or referenced to a generally accepted document that shows such arrangements.*

5.2—Types of bar supports

5.2.1 Wire bar supports—Descriptions of wire bar supports and examples of their usage are available as industry recommendations in the CRSI *Manual of Standard Practice*, which is revised periodically to reflect the latest practice. *Caution:* When multiple layers of unusually heavy reinforcing bars are to be supported on wire bar supports, the number of wire bar supports may need to be increased to prevent penetration of support legs into the form material, especially where the surface is exposed to view or corrosion.

5.2.2 Precast concrete bar supports—Descriptions of commonly used types and sizes are available in the CRSI

Manual of Standard Practice. Requirements for texture and color to suit job conditions should be added if necessary. *Caution:* If the finished surface will be subjected to sand-blasting, bush-hammering, or chemical removal of external mortar, the different texture of the exposed precast blocks (unless part of a planned pattern) may be objectionable.

5.2.3 Other types of bar supports—CRSI's *Manual of Standard Practice* contains descriptions of one other type of bar supports, all-plastic bar supports. See the supporting reference data section for more information.

5.3—Side form spacers and beam bolsters

All reinforcing steel must be firmly held in place before and during casting of concrete by means of precast concrete blocks, metallic or plastic supports, spacer bars, wires, or other devices adequate to ensure against displacement during construction and to keep the reinforcing steel at the proper distance from the forms. Selection of the type of spacer traditionally has been the responsibility of the contractor. Detailing of side form spacers is not a standard requirement and is performed only when specifically required by the contract documents. The reinforcing bar placing drawings need only show, and the fabricator will only be responsible to supply, those side form spacers that are equal to the standard bar supports referred to in Section 5.2.

Beam bolsters are typically placed transversely to the beam. Beam bolsters placed longitudinally with the beam are supplied only upon special arrangements between the contractor and the supplier, if approved by the A/E.

5.4—Placing reinforcing steel supports

5.4.1 General—Reinforcing steel must be accurately located in the forms and firmly held in place before and during the placing of concrete. Adequate supports are necessary to prevent displacement during construction and to keep the reinforcing steel at a proper distance from the forms. Bar supports are sometimes specified to be “sufficient in number and strength to carry properly the reinforcing steel they support.” The detailer should show bar supports as required.* Bar supports are detailed for shrinkage-temperature reinforcing steel in top slabs of reinforced concrete joist construction only if specifically required in the contract documents.

Bar supports are not intended to and should not be used to support runways for concrete buggies or similar loads.

5.4.2 Supports for bars in reinforced concrete cast on ground—Bar supports are detailed for the top bars only in slabs on grade, grade beams, footings, and foundation mats 4 ft (1200 mm) or less in thickness, in quantities not to exceed an average spacing of 4 ft (1200 mm) in each direction. Separate support bars are detailed only if so indicated by the A/E or on special arrangements with the contractor, as principal reinforcement is assumed to be used for support.

Bar supports will be furnished by the reinforcing-steel supplier for bottom bars in grade beams or slabs on ground and for the bars in singly reinforced slabs on ground only if specifically required in the contract documents. There are so many ways of supporting top bars in footings and foundation

*Suggested sizes, styles, and placing of bar supports are shown in Chapter 3 (Bar Supports) of the supporting reference data section.

mats more than 4 ft (1200 mm) thick that suppliers furnish supports for such purposes only by special arrangement.

CHAPTER 6—COMPUTER-ASSISTED DETAILING

6.1—Use of computers in detailing

The computer system for detailing reinforcing bars has been devised to use digital computers and other data processing equipment to speed up the preparation of placing drawings, to facilitate neater and more compact drawings, and to relieve the detailer of tedious and time-consuming computations that can be performed efficiently by a computer.

Computer-aided drafting, commonly called CAD, is also being used in the drawing and detailing of placing drawings. This system gives the detailer speed, accuracy, and an expeditious way of making changes when necessary.

6.2—Placing drawings

The detailer prepares the graphical part of the placing drawing in a conventional manner. All the listing of quantities and other descriptive printing, however, is performed by the computer's output device (that is, plotter, matrix printer, laser printer). While producing the placing drawings, the detailer may directly or indirectly input information into the computer for processing. When the input data have been processed, the drawing is completed by attaching to it the printed output from the computer. It contains all the necessary descriptive information pertaining to the reinforcing steel as well as the bending details. Computer output can be printed on transparent paper so that bar lists and bending details will be reproduced as part of the placing drawing.

The "label system" is often used to reference the bars on the drawing with its attached machine printout. Under this system, the detailer assigns a label number to each separate bar placing operation comprising either an individual bar or a group of bars. This label number, indicating the designated bars, is shown clearly on the drawing and is also written on the input sheet along with other pertinent data, such as bar size and spacing. The output from the computer prints the label number and then lists the descriptions of the various bars under each label. In this way, a quick reference can be made between the graphical section of the drawing and the machine printed bar descriptions.

6.3—Ordering procedures

When the placing drawings have been approved, preparation of shop orders is greatly simplified by using the data already generated for the label list or column or beam and slab schedule and bending details. All the detailer must indicate are the labels or the portions thereof that are to be ordered from a particular drawing, and the data processing equipment weighs and sorts and lists the material by grade, tag color, type of bending, and size and length in descending order on the bar list. The equipment can also produce the shipping tags and all manifest documents.

CHAPTER 7—RECOMMENDED PRACTICES FOR LOCATION OF BARS DESIGNATED ONLY BY SIZE/SPACING

Especially in slabs and walls designed for a given area of reinforcing steel per running foot, required reinforcement

commonly is designated by size and spacing combinations to the nearest 1/2 in. (10 mm) for spacing. If the structural drawing specifically shows the positions of the first bar per panel, or for a given length shows the total number of bars, no problem is created—the detailer simply follows the specific requirements. Therefore, design notes, such as 20-No. 4 (20-No. 13) in a designated length, or No. 4 at 12 (No. 13 at 300 mm) with location of the starting bar shown, requires no further interpretation to complete a placing drawing or to calculate total number of bars required. When the structural drawing shows No. 4 at 12 (No. 13 at 300 mm) with no further instructions in the general notes or in the project specifications, the procedures shown in Fig. 19 (in Part C) are recommended.

CHAPTER 8—GLOSSARY

Architect/engineer—The architect, engineer, architectural firm, engineering firm, or architectural and engineering firm, issuing project drawings and specifications, or administering work under the contract documents.

Bar placing subcontractor—A contractor or subcontractor who handles and places reinforcement and bar supports, often colloquially referred to as a bar placer or placer.

Bar supports—Devices of formed wire, plastic or precast concrete to support, hold, and space reinforcing bars.

Butt-welded splice—Reinforcing bar splice made by welding the butted ends of the reinforcing bars.

Contract documents—Documents, including the project drawings and project specifications, covering the required work.

Contractor—Person, firm, or corporation with whom the owner enters into an agreement for construction of the work.

Coupler—Threaded device for joining reinforcing bars for the purpose of providing transfer of either axial compression or axial tension or both from one bar to the other.

Coupling sleeve—Nonthreaded device fitting over the ends of two reinforcing bars for the eventual purpose of providing transfer of either axial compression or axial tension or both from one bar to the other.

Detailer—Drafter who prepares reinforcing bar placing drawings and bar lists.

Fabricator—A bar company that is capable of preparing placing drawings, bar lists, and storing, shearing, bending, bundling, tagging, loading, and delivering reinforcing bars.

Mechanical splice—The complete assembly of an end-bearing sleeve, a coupler, or a coupling sleeve, and possibly additional materials or parts to accomplish the connection of reinforcing bars.

Owner—Corporation, association, partnership, individual, or public body or authority with whom the contractor enters into agreement, and for whom the work is provided.

Placing drawings—Detailed drawings or sketches that give the size, location, and spacing of the bars, and all other information required by the contractor to place the reinforcing steel.

Project drawings—The drawings which, along with project specifications, complete the descriptive information for con-

structing the work required or referred to in the contract documents.

Project specifications—The written documents that specify requirements for a project in accordance with the service parameters and other specific criteria established by the owner.

Schedule—Table on placing drawings to give the size, shape, and arrangement of similar items.

Sleeve—A tube that encloses such items as a bar, dowel, or anchor bolt.

Splice—Connection of one reinforcing bar to another by lapping, mechanical coupling or welding; the lap between sheets or rolls of welded-wire fabric.

Structural drawings—Drawings that show all framing plans, sections, details, and elevations required to construct the work. For reinforced-concrete structures, they include the sizes and general arrangement of all the reinforcement from which the fabricator prepares the placing drawings.

Welded splice—A means of joining two reinforcing bars by electric arc welding. Reinforcing bar may be lapped, butted, or joined with splice plates or angles.

Work—The entire construction, or separately identifiable parts thereof, which are required to be furnished under the contract documents. Work is the result of performing services, furnishing labor, and furnishing and incorporating materials and equipment into the construction, as required by the contract documents.

CHAPTER 9—REFERENCES

9.1—Referenced standards

The documents of the various organizations referred to in this standard are listed below with their serial designation, including year of adoption or revision. The documents listed were the latest edition at the time this standard was revised. Because some of these documents are revised frequently, generally in minor detail only, the user of this standard should check directly with the sponsoring group if it is desired to refer to the latest revision.

American Association of State Highway and Transportation Officials

AASHTO Standard Specifications for Highway Bridges, 16th Edition 1996

American Concrete Institute

- 117-90 Standard Tolerances for Concrete Construction and Materials
- 318-95 Building Code Requirements for Structural Concrete
- 318M-95 Building Code Requirements for Structural Concrete (Metric)
- 343R-95 Analysis and Design of Reinforced Concrete Bridge Structures
- 349-97 Code Requirements for Nuclear Safety Related Concrete Structures
- 359-92 Code for Concrete Reactor Vessels and Containments

American Railway Engineering and Maintenance-of-Way Association

Manual for Railway Engineering, Chapter 8, Concrete Structures and Foundations, 1996

American Society for Testing and Materials

- A 82-97a Standard Specification for Steel Wire, Plain, for Concrete Reinforcement
- A 185-97 Standard Specification for Steel Welded Wire Fabric, Plain, for Concrete Reinforcement
- A 496-97a Standard Specification for Steel Wire, Deformed, for Concrete Reinforcement
- A 497-97 Standard Specification for Steel Welded Wire Fabric, Deformed, for Concrete Reinforcement
- A 615/ Standard Specification for Deformed and
- A 615M-96a Plain Billet-Steel Bars for Concrete Reinforcement
- A 616/ Standard Specification for Rail-Steel
- A 616M-96a Deformed and Plain Bars for Concrete Reinforcement
- A 617/ Standard Specification for Axle-Steel
- A 617M-96a Deformed and Plain Bars for Concrete Reinforcement
- A 706/ Standard Specification for Low-Alloy
- A 706M-96b Steel Deformed and Plain Bars for Concrete Reinforcement
- A 767/ Standard Specification for Zinc-Coated
- A 767M-97 (Galvanized) Steel Bars for Concrete Reinforcement
- A 775/ Standard Specification for Epoxy-Coated
- A 775M-97 Reinforcing Steel Bars

American Society of Civil Engineers

ASCE 7-95 Minimum Design Loads for Buildings and Other Structures

American Welding Society

DI.4-98 Structural Welding Code—Reinforcing Steel

Association for Information and Image Management

Modern Drafting Techniques for Quality Microreproductions

Building Seismic Safety Council

NEHRP-97 NEHRP Recommended Provisions for Seismic Regulations for New Buildings

Concrete Reinforcing Steel Institute

Manual of Standard Practice, 26th Edition, 2nd Printing, 1998
Reinforcement Anchorages and Splices, 4th Edition 1997

International Conference of Building Officials

Uniform Building Code, 1997

These publications can be obtained from the following organizations:

American Association of State Highway and Transportation Officials

444 North Capitol Street, N.W., Suite 249

Washington, D.C. 20001

American Concrete Institute
P.O. Box 9094
Farmington Hills, Mich. 48333-9094

American Railway Engineering and Maintenance-of-Way Association
50 F Street, N.W.
Washington, D.C. 20001

American Society for Testing and Materials
100 Barr Harbor Drive
West Conshohocken, Pa. 19428

American Society of Civil Engineers
1801 Alexander Bell Drive
Reston, Va. 20191

American Welding Society
550 N.W. LeJeune Road
Miami, Fla. 33126

Association for Information and Image Management
1100 Wayne Avenue, Suite 1100
Silver Springs, Md. 20910

Building Seismic Safety Council
1015 15th Street, N.W., Suite 700
Washington, D.C. 20005

Concrete Reinforcing Steel Institute
933 North Plum Grove Road
Schaumburg, Ill. 60173

International Conference of Building Officials
5360 South Workman Mill Road
Whittier, Calif. 90601

9.2—Cited references

1. Collins, M. P., and Mitchell, D., "Detailing for Torsion," *ACI JOURNAL, Proceedings* V. 73, No. 9, Sept. 1976, pp. 506-511.
2. Guimaraes, G. N.; Kreger, M. E.; and Jirsa, J. O., "Reinforced Concrete Frame Connections Constructed Using High-Strength Materials," University of Texas at Austin, Aug. 1989 (PMFSEL Report No. 89-1).

CHAPTER 10—NOTATIONS

- A_c = area of core of spirally reinforced compression member measured to outside diameter of spiral, in.² (mm²)
- A_{cv} = net area of concrete section bounded by web thickness and length of section in the direction of shear force considered, in.² (mm²)
- A_g = gross area of section, in.² (mm²)
- A_s = area of nonprestressed tension reinforcement, in.² (mm²)
- b_w = web width, in. (mm)
- c_2 = size of rectangular or equivalent rectangular column, capital, or bracket measured transverse to the direction of the span for which moments are being determined, in. (mm)
- d = distance from extreme compression fiber to centroid of tension reinforcement, in. (mm)
- d_b = bar diameter, in. (mm)
- f'_c = specified compressive strength of concrete, psi (MPa)
- f_y = specified yield strength of nonprestressed reinforcement, psi (MPa)
- h = overall thickness of member, in. (mm)
- ℓ_d = development length, in. (mm)
- ℓ_{dh} = development length for a bar with a standard hook, in. (mm)
- ℓ_o = minimum length, measured from joint face along axis of structural member, over which transverse reinforcement must be provided, in. (mm)
- M_u = factored moment at section
- s = spacing of shear or torsion reinforcement in direction parallel to longitudinal reinforcement, in. (mm)
- s_o = maximum spacing of transverse reinforcement, in. (mm)
- ρ = ratio of nonprestressed tension reinforcement
- ρ_v = A_{sv}/A_{cv} ; where A_{sv} is the projection on A_{cv} of area of distributed shear reinforcement crossing the plane of A_{cv}

MANUAL OF CONCRETE PRACTICE
PART C—FIGURES AND TABLES

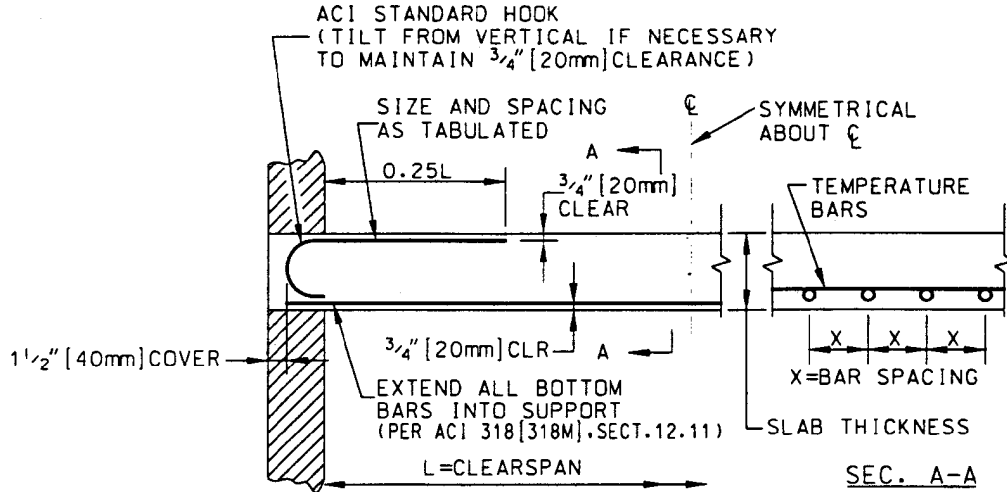

SINGLE SPAN, SIMPLY SUPPORTED

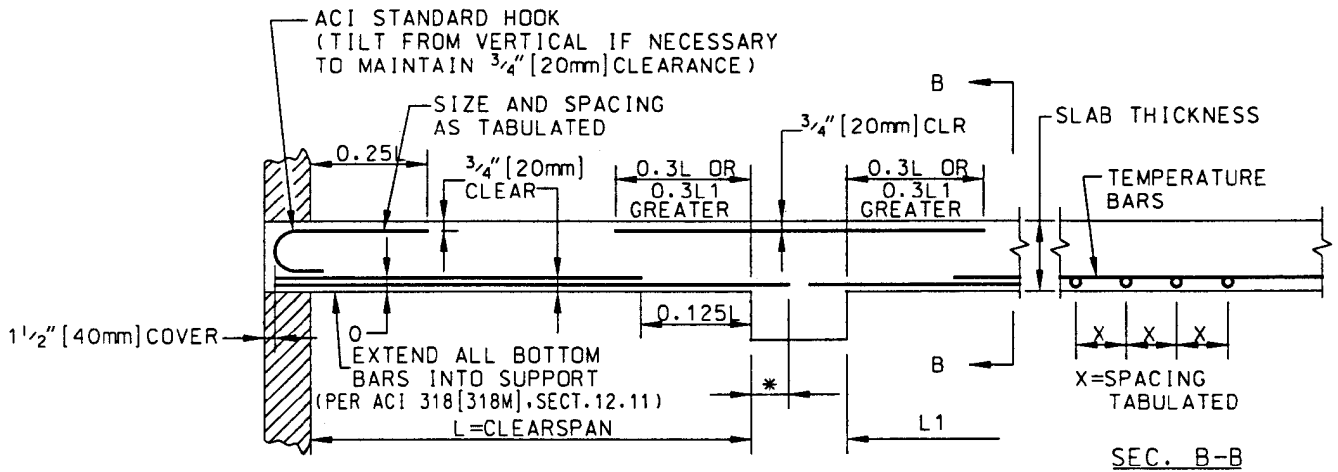

END SPAN, SIMPLY SUPPORTED

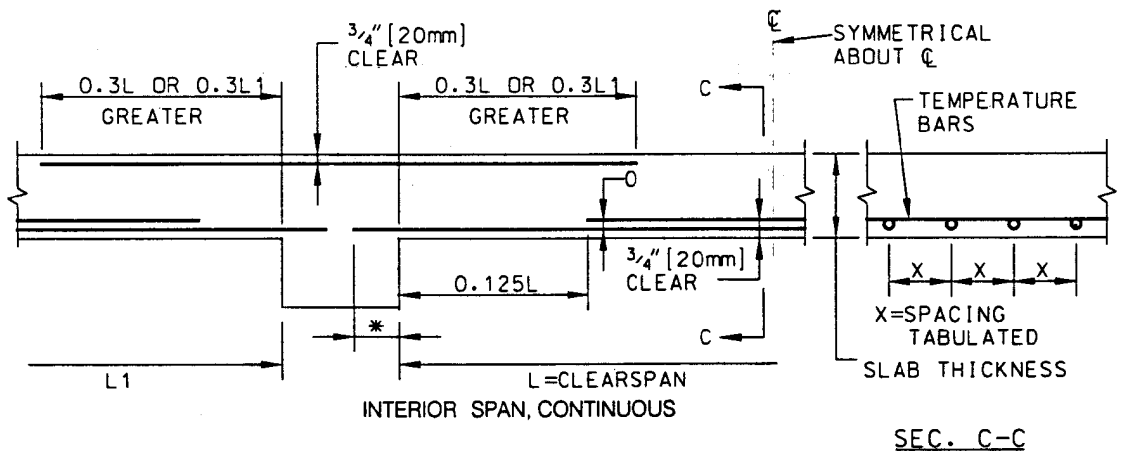

* MIN. 6" [150mm], UNLESS OTHERWISE SPECIFIED BY THE ARCHITECT/ENGINEER

Note: Unless noted otherwise, tables and figures are based on ACI 318 (318M). Concrete cover shown is minimum and should be increased for more severe conditions. Except for single span slabs where top steel is unlikely to receive construction traffic, top bars lighter than No. 4 at 12 in. (No. 13 at 300 mm) are not recommended. For a discussion of bar support spacing, see Section 5.4 of this standard. See also Chapter 12 of ACI 318 (318M). Bar cutoff details must be verified to provide required development of reinforcement.

Fig. 1—Typical details for one-way solid slabs.

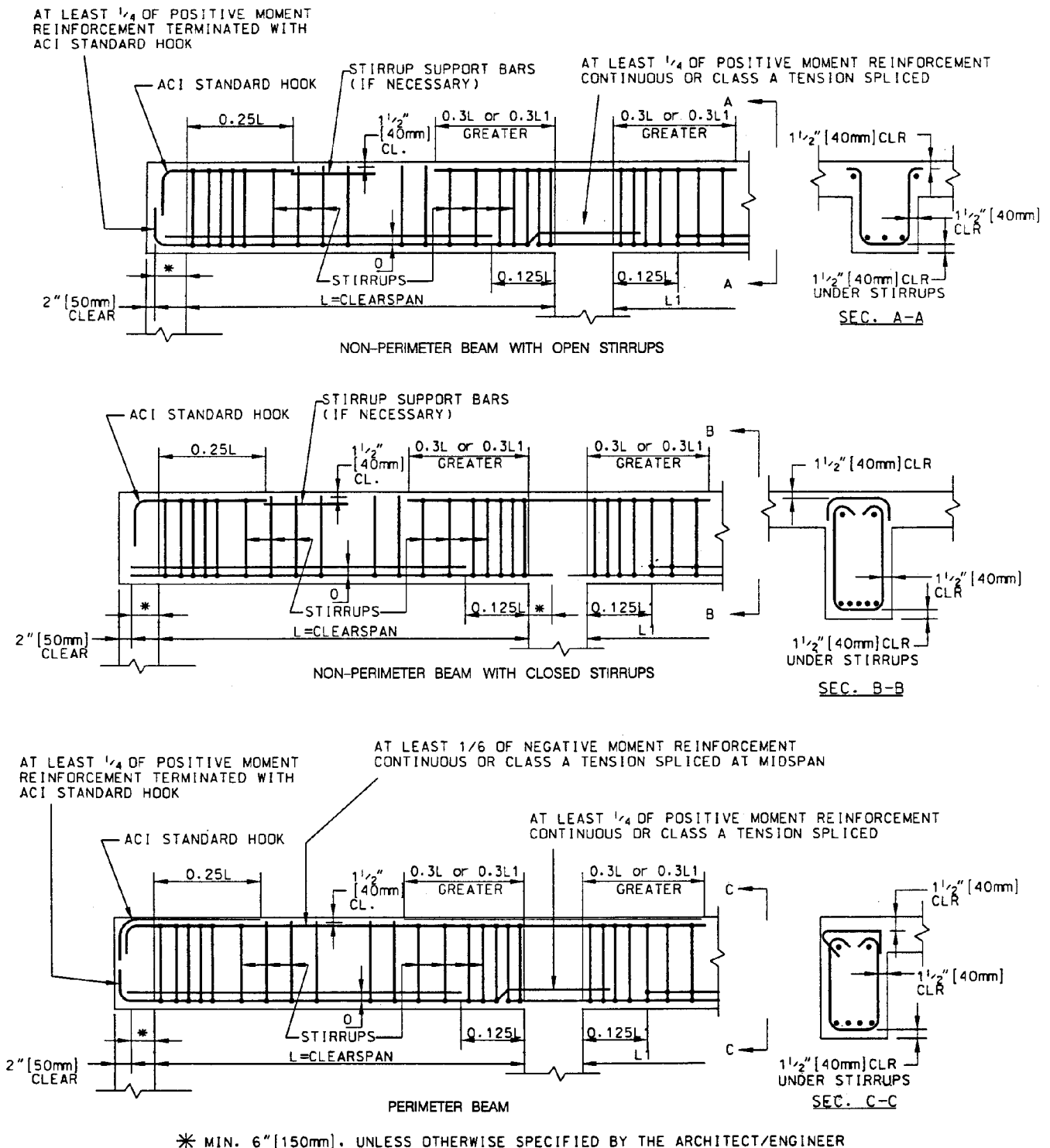
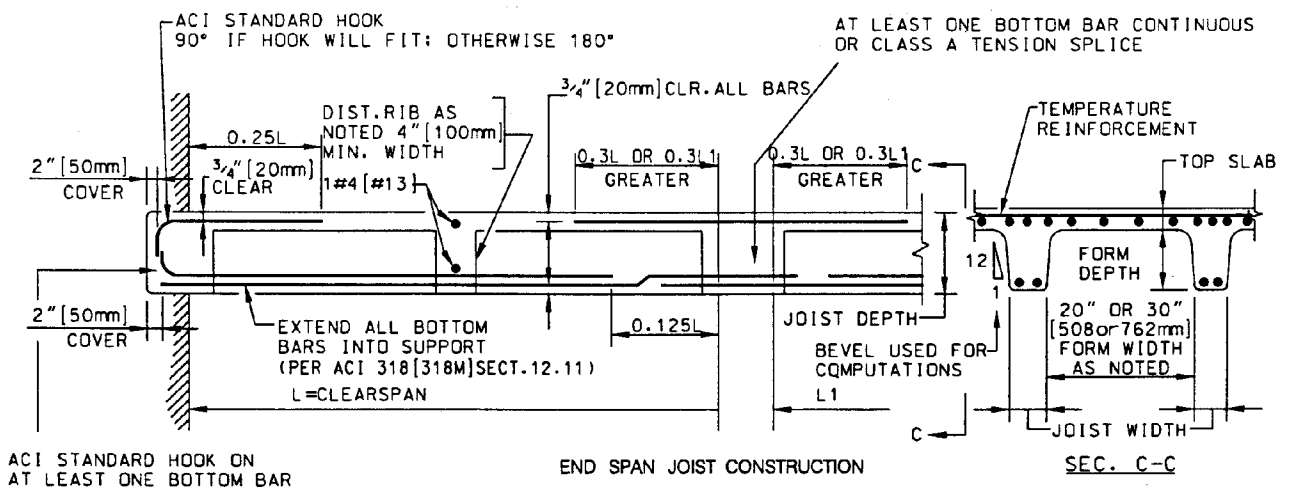
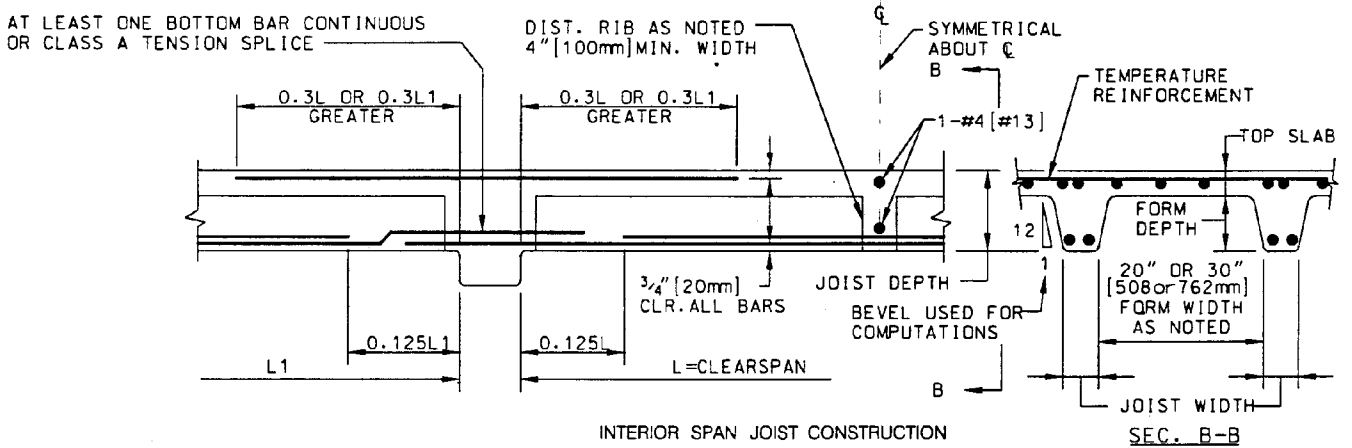
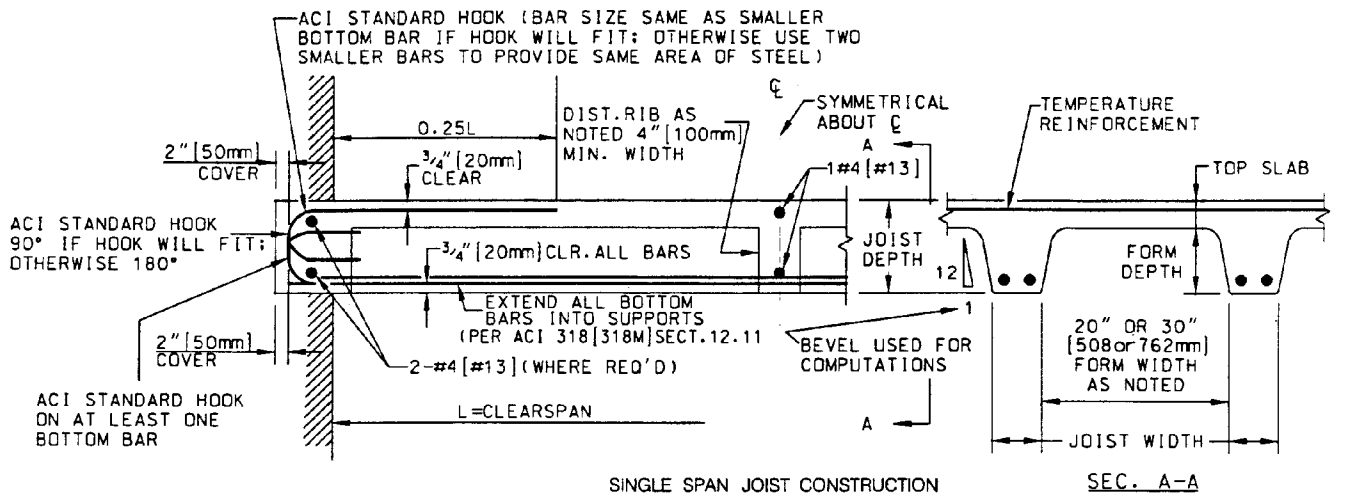
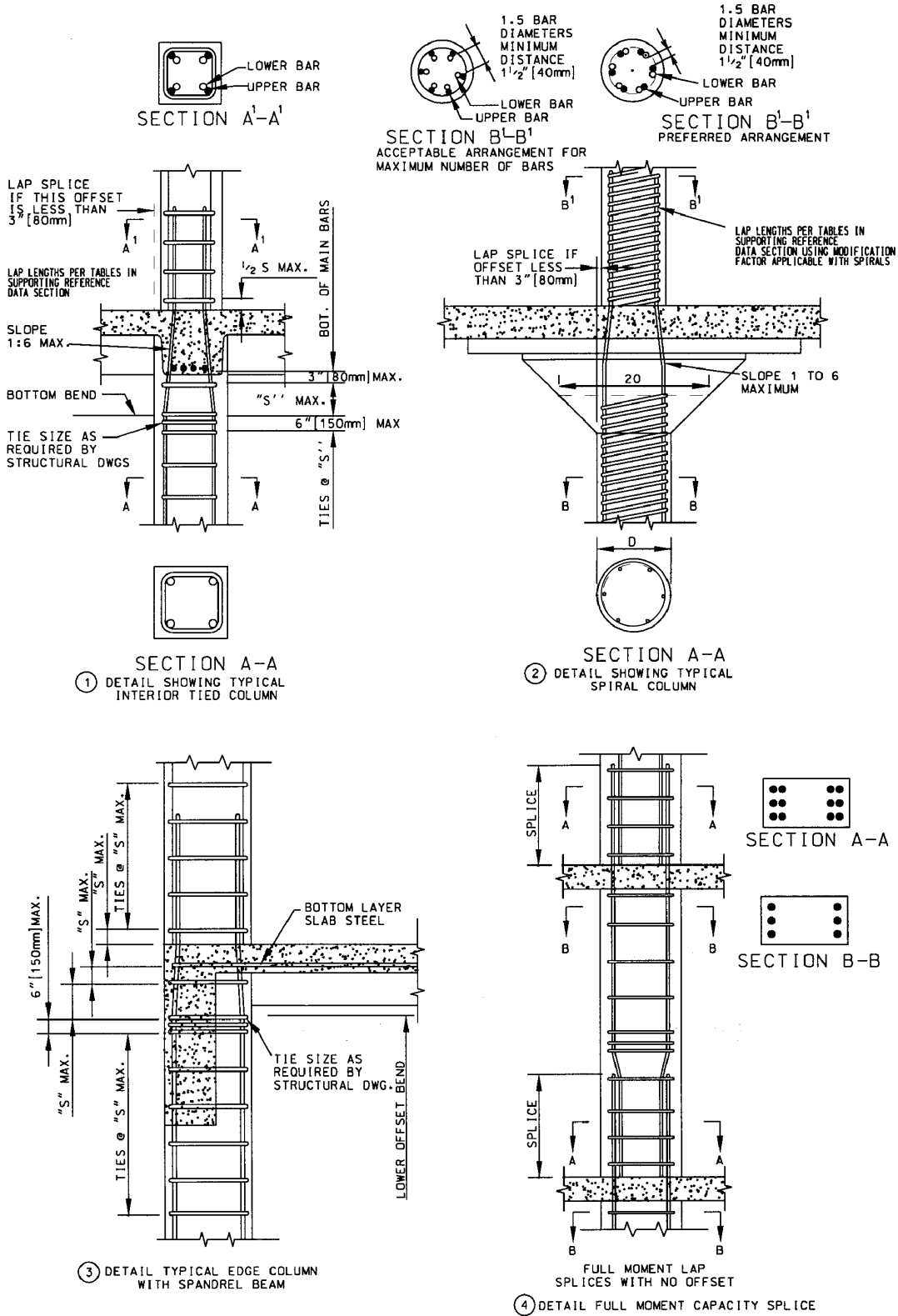

Fig. 2—Typical details for beams.



Note: See also Chapter 12 and Section 7.13 of ACI 318 (318M). Bar cutoff details must be verified to provide required development of reinforcement.

Fig. 3—Typical details for one-way joist construction.



Note: Where column size above is unchanged from below, "upside down" offset bars are effective in maintaining full moment capacity at end of column. In U.S. practice, this unusual detail is rare, and should be fully illustrated on structural drawings to avoid misunderstandings, whenever its use is deemed necessary. For maximum tie spacing, see table in Supporting Reference Data section.

Fig. 4—Column splice details.

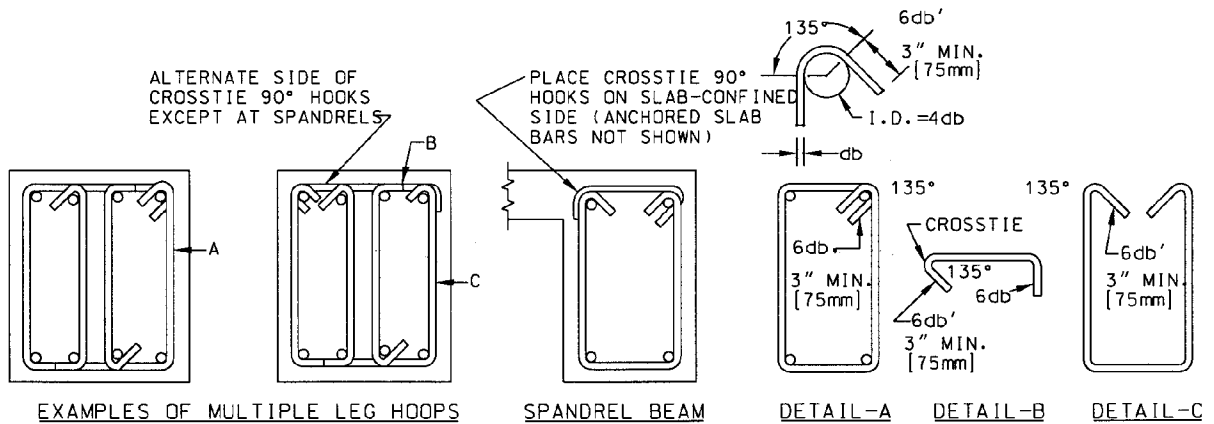
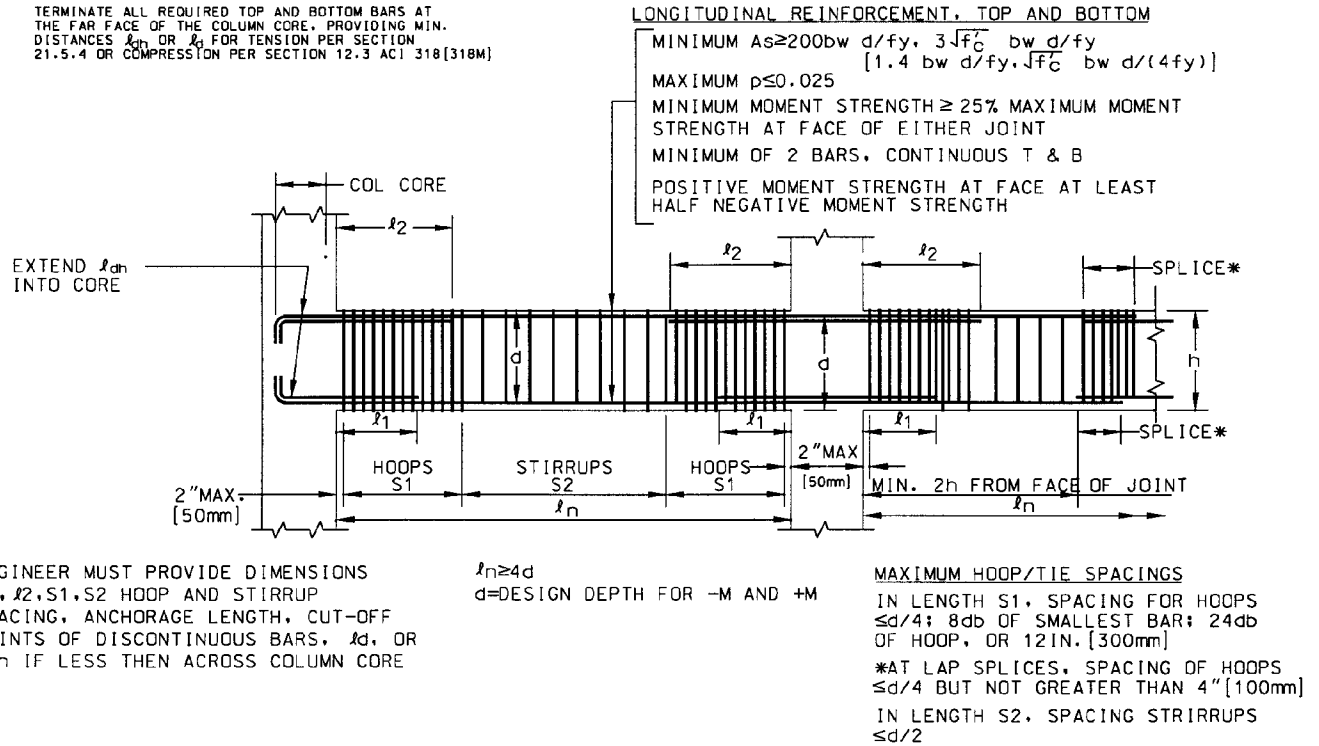

STIRRUPS REQUIRED TO RESIST SHEAR SHALL BE HOOPS OVER LENGTH AS SPECIFIED IN ACI 21.3.3.5. THROUGHOUT THE LENGTH OF FLEXURAL MEMBERS WHERE HOOPS ARE NOT REQUIRED, STIRRUPS MUST BE SPACED AT NO MORE THAN $d/2$

Fig. 5—Typical seismic-resistant details: flexural members.

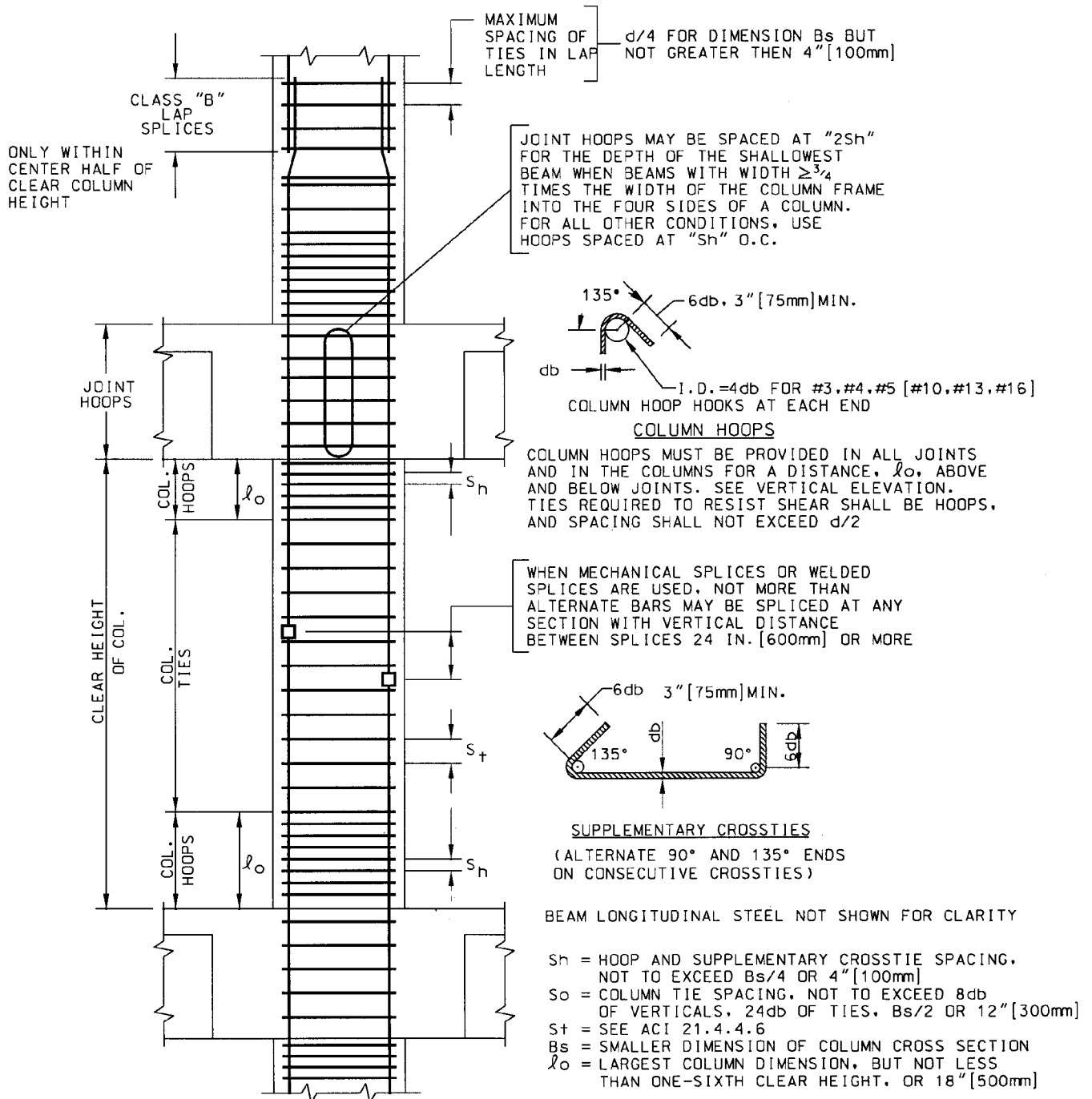
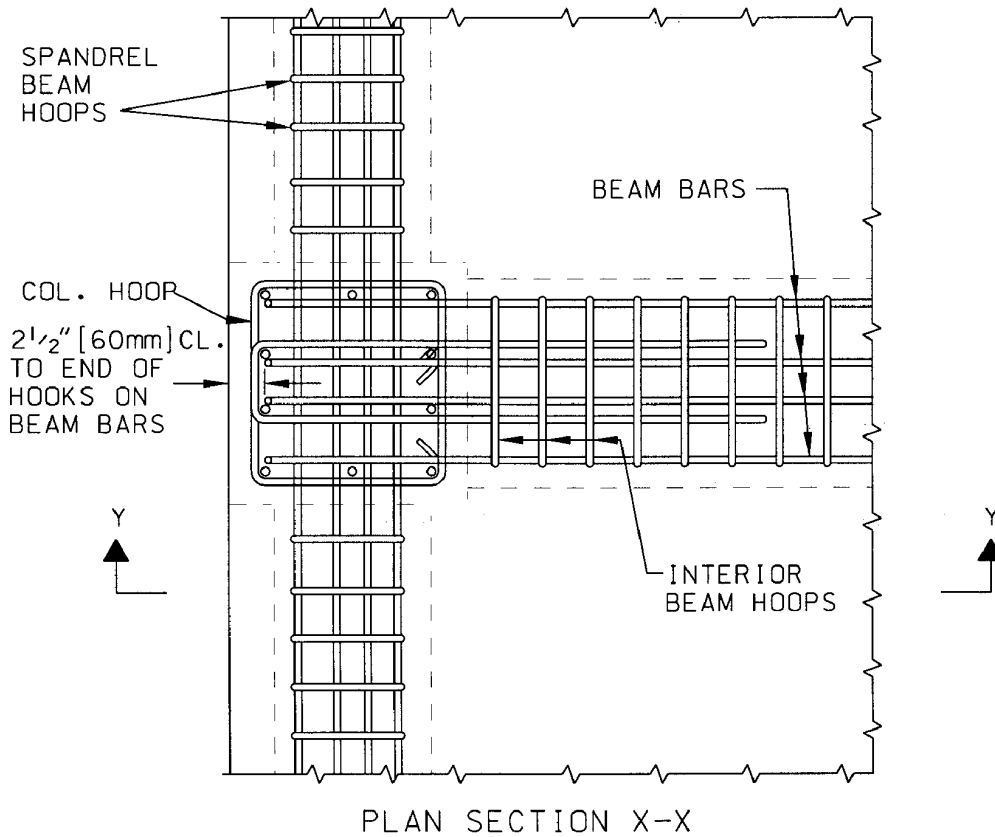
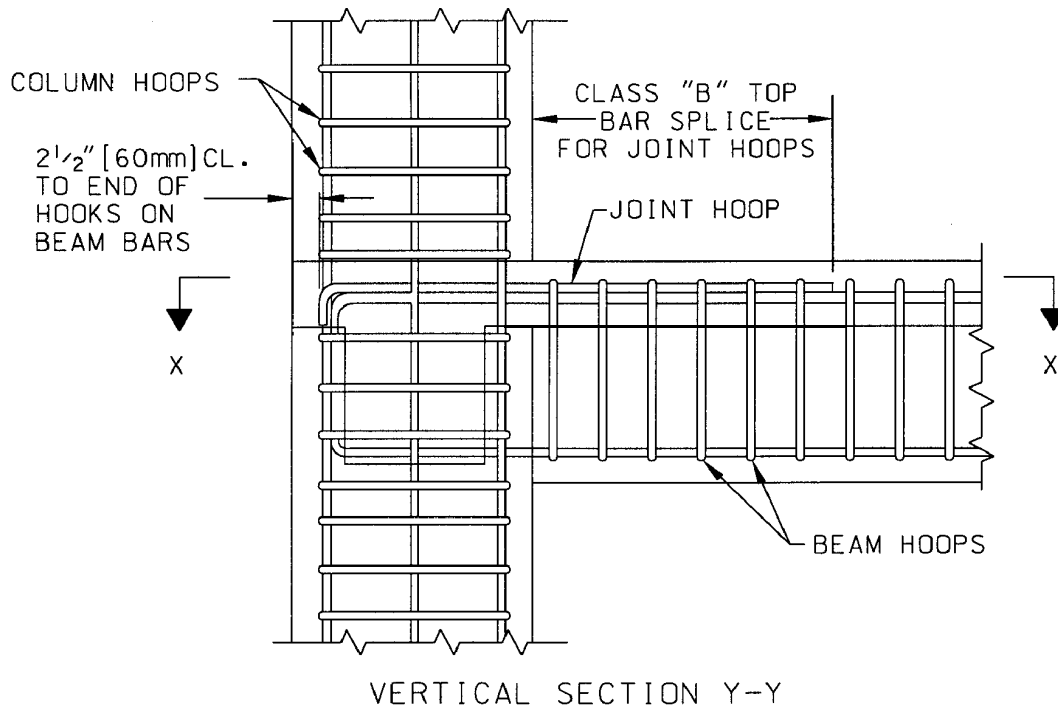

Fig. 6—Typical seismic-resistant details: columns.



NOTE: ROUND COLUMNS CAN HAVE EITHER HOOPS OR SPIRALS

Fig. 7(a)—Typical seismic-resistant joint details—Case 1: For regions of high seismic risk. Interior and spandrel beams narrower than column.

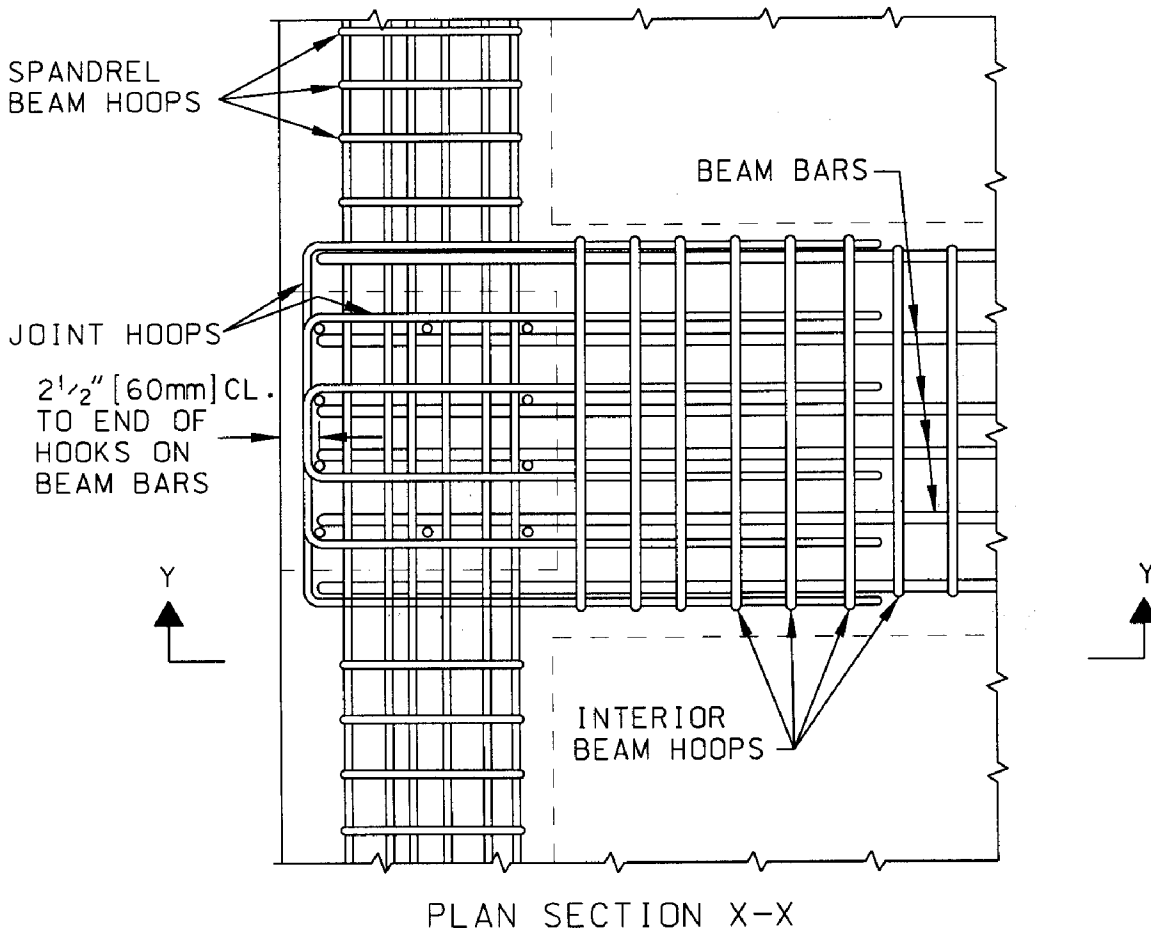
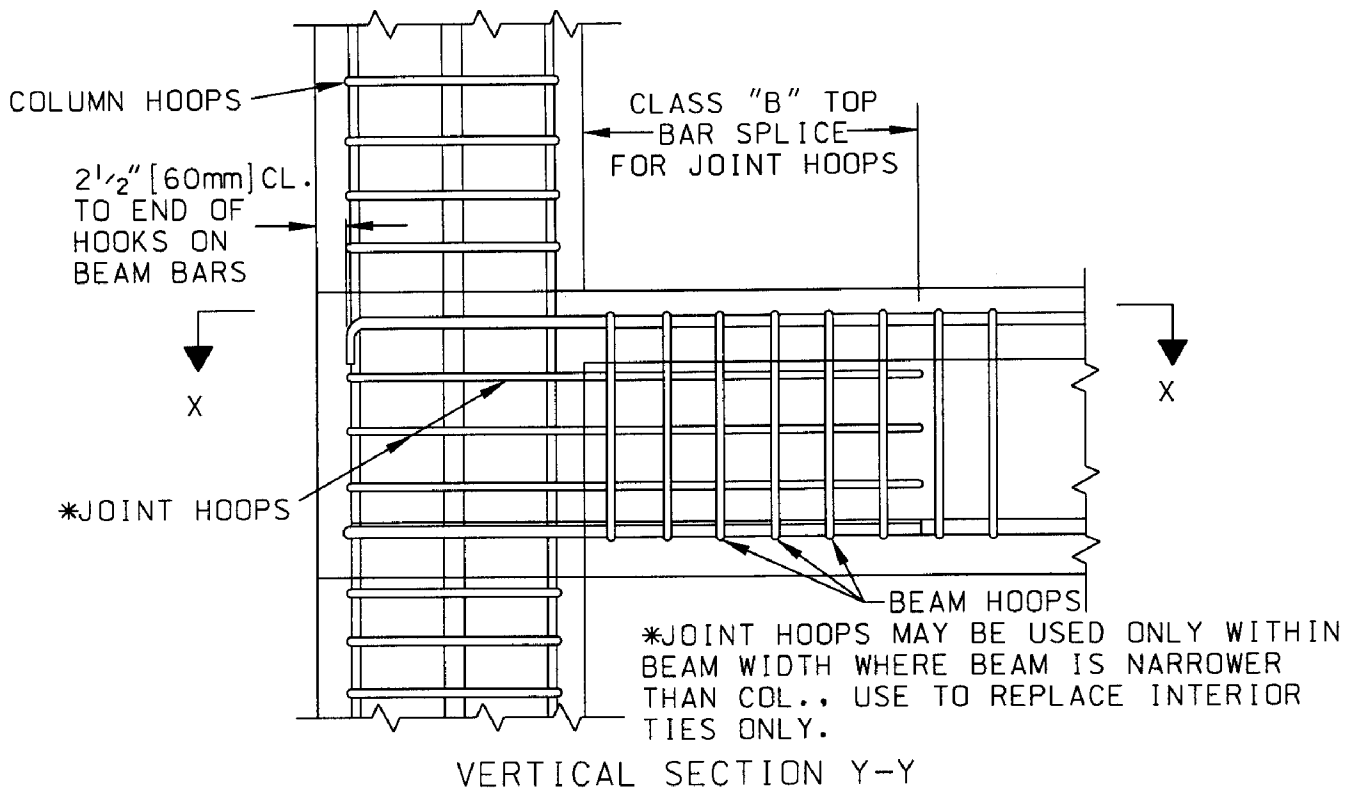

Fig. 7(b)—Typical seismic-resistant joint details—Case 2: For regions of moderate seismic risk. Interior beam wider than column; spandrel beams narrower than column.

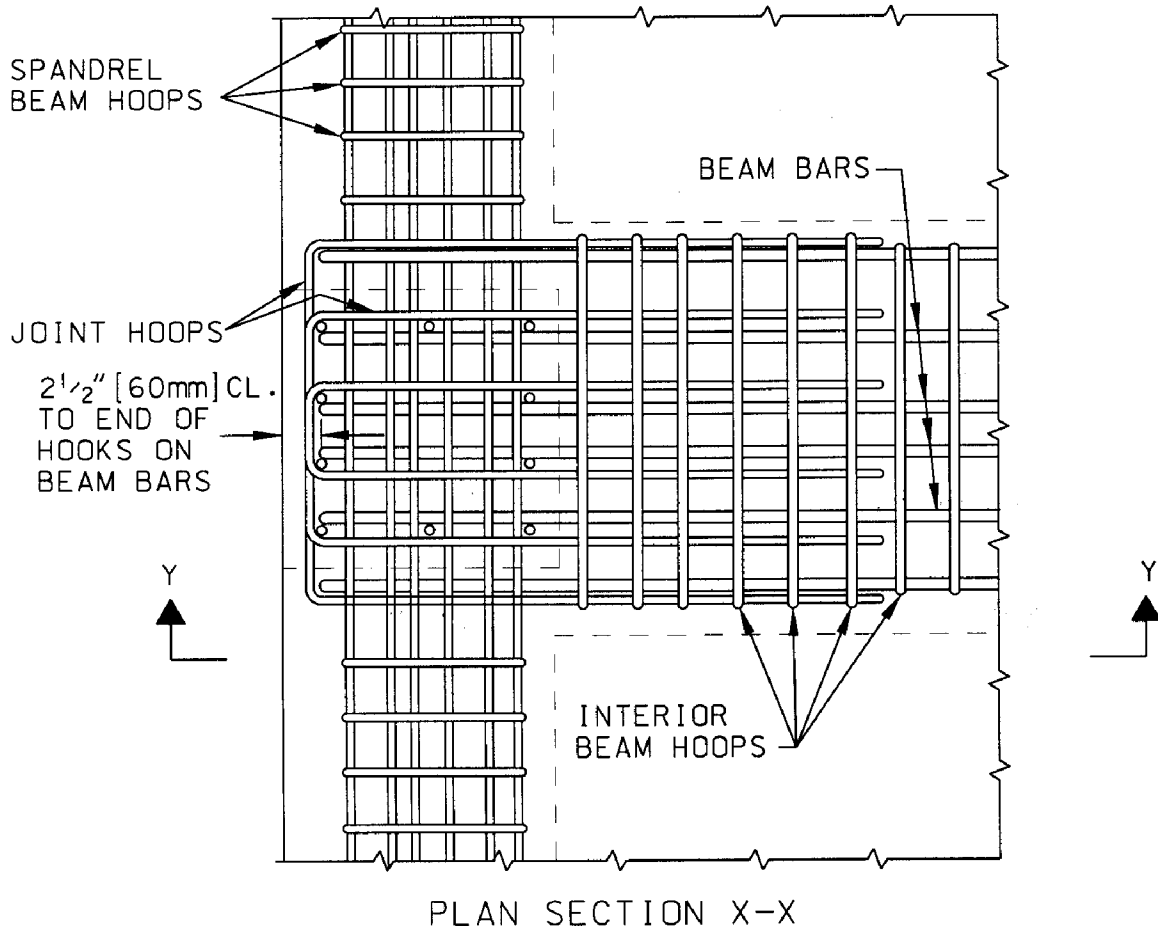
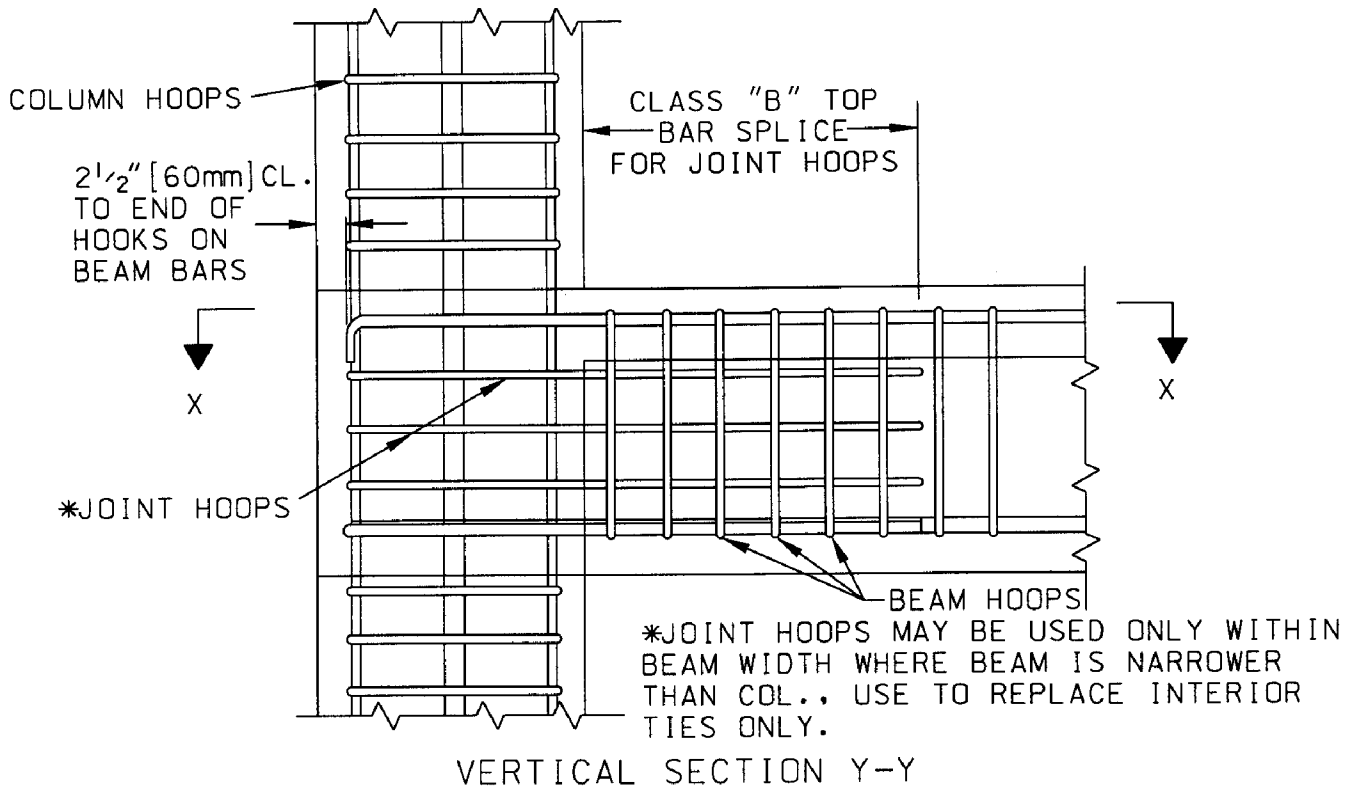
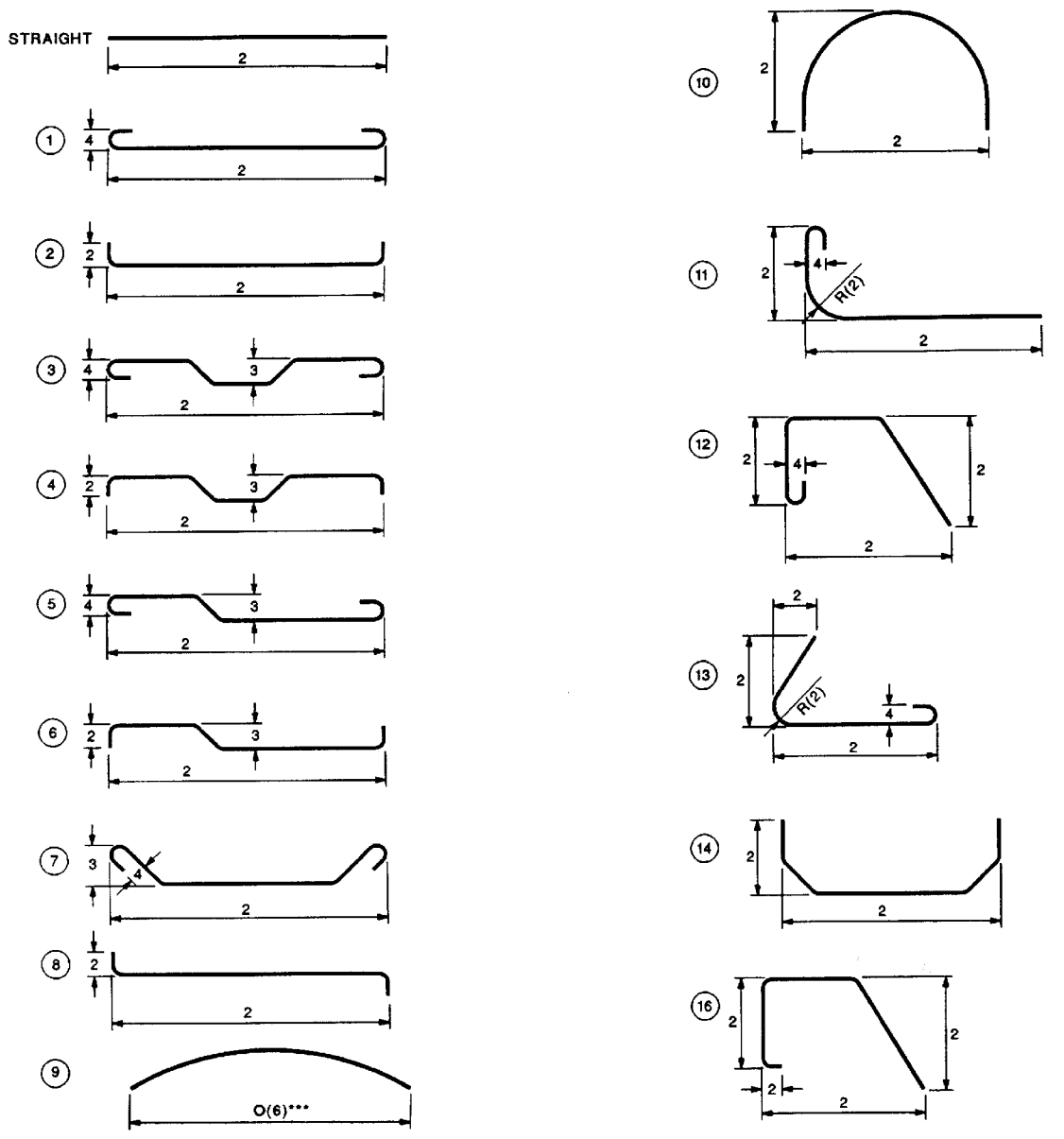

Fig. 7(c)—Typical seismic-resistant joint details—Case 3: For regions of moderate seismic risk. Interior beam wider than column; spandrel beam is same width as column.



TOLERANCE SYMBOLS

1	= ±1/2 in. (15 mm) for bar size No. 3, 4, and 5 (No. 10, 13, and 16) (gross length < 12 ft. 0 in. (3650 mm))
1	= ±1 in. (25 mm) for bar size No. 3, 4, and 5 (No. 10, 13, and 16) (gross length ≥ 12 ft. 0 in. (3650 mm))
1	= ±1 in. (25 mm) for bar size No. 6, 7, and 8 (No. 19, 22, and 25)
2	= ± 1 in. (25 mm)
3	= + 0, -1/2 in. (15 mm)
4	= ±1/2 in. (15 mm)
5	= ±1/2 in. (15 mm) for diameter ≤ 30 in. (760 mm)
5	= ±1 in. (25 mm) for diameter > 30 in. (760 mm)
6	= ± 1.5% × "O" dimension, ≥ ± 2 in. (50 mm) minimum

SEE NOTE ANGULAR DEVIATION**

Note: All tolerances single plane and as shown.
 *Dimensions on this line are to be within tolerance shown but are not to differ from the opposite parallel dimension more than 1/2 in. (15 mm).
 **Angular deviation—maximum ± 2-1/2 degrees or ± 1/2 in./ft (40 mm/m), but not less than 1/2 in. (15 mm) on all 90 degree hooks and bends.
 ***If application of positive tolerance to Type 9 results in a chord length ≥ the arc or bar length, the bar may be shipped straight.
 Tolerances for Types S1-S6, S11, T1-T3, T6-T9 apply to bar size No. 3 through 8 (No. 10 through 25) inclusive only.

Fig. 8—Standard fabricating tolerances for bar sizes No. 3 through 11 (No. 10 through 36).

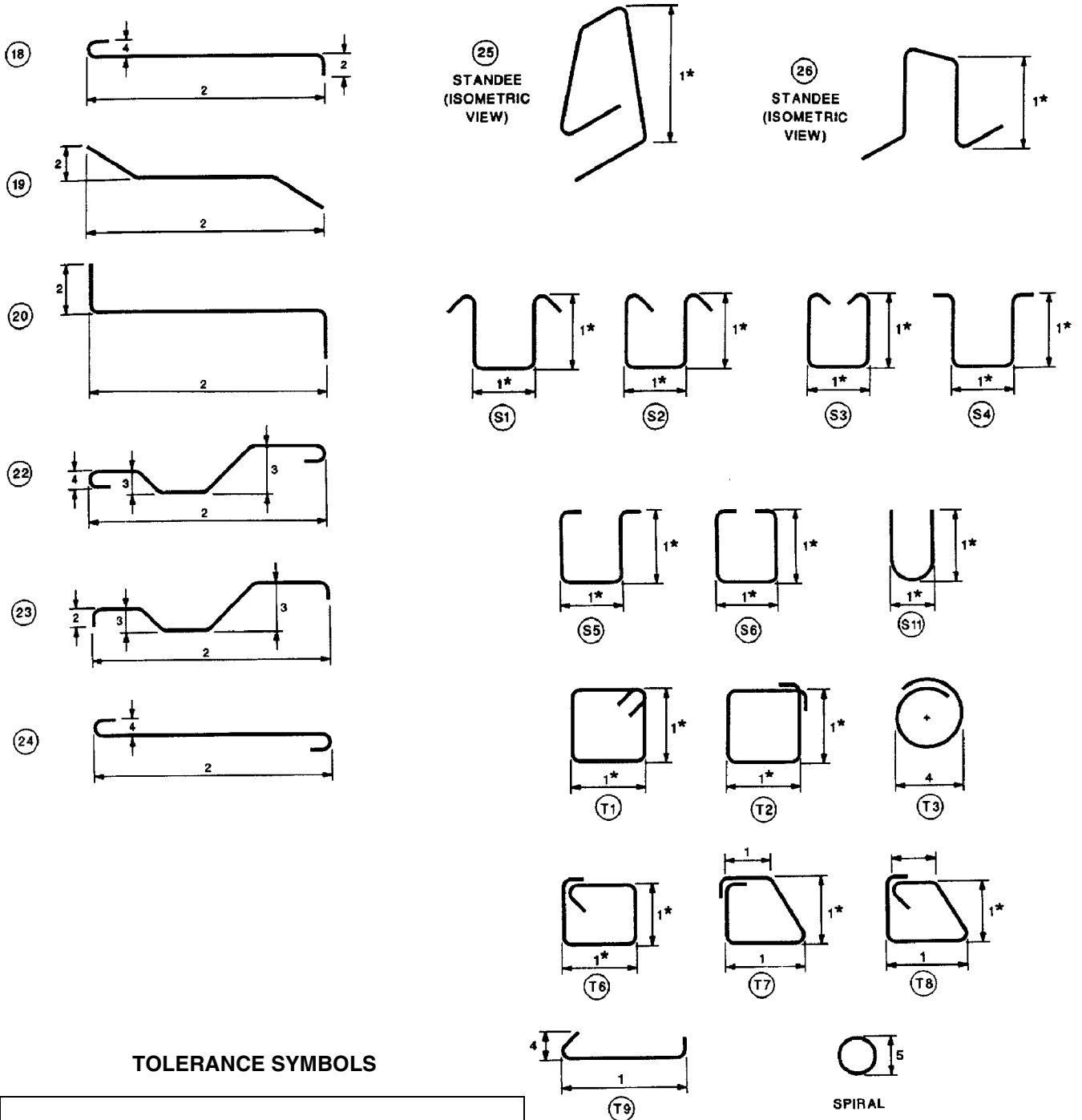

TOLERANCE SYMBOLS

1	= ±1/2 in. (15 mm) for bar size No. 3, 4, and 5 (No. 10, 13, and 16) (gross length < 12 ft. 0 in. (3650 mm))
1	= ±1 in. (25 mm) for bar size No. 3, 4, and 5 (No. 10, 13, and 16) (gross length ≥ 12 ft. 0 in. (3650 mm))
1	= ±1 in. (25 mm) for bar size No. 6, 7, and 8 (No. 19, 22, and 25)
2	= ± 1 in. (25 mm)
3	= + 0, -1/2 in. (15 mm)
4	= ±1/2 in. (15 mm)
5	= ±1/2 in. (15 mm) for diameter ≤ 30 in. (760 mm)
5	= ±1 in. (25 mm) for diameter > 30 in. (760 mm)
6	= ± 1.5% × "O" dimension, ≥ ± 2 in. (50 mm) minimum

Note: All tolerances single plane and as shown.
 *Dimensions on this line are to be within tolerance shown but are not to differ from the opposite parallel dimension more than 1/2 in. (15 mm).
 **Angular deviation—maximum ± 2-1/2 degrees or ± 1/2 in./ft (40 mm/m), but not less than 1/2 in. (15 mm) on all 90 degree hooks and bends.
 ***If application of positive tolerance to Type 9 results in a chord length ≥ the arc or bar length, the bar may be shipped straight.
 Tolerances for Types S1-S6, S11, T1-T3, T6-T9 apply to bar size No. 3 through 8 (No. 10 through 25) inclusive only.

Fig. 8 (cont.)—Standard fabricating tolerances for bar sizes No. 3 through 11 (No. 10 through 36).

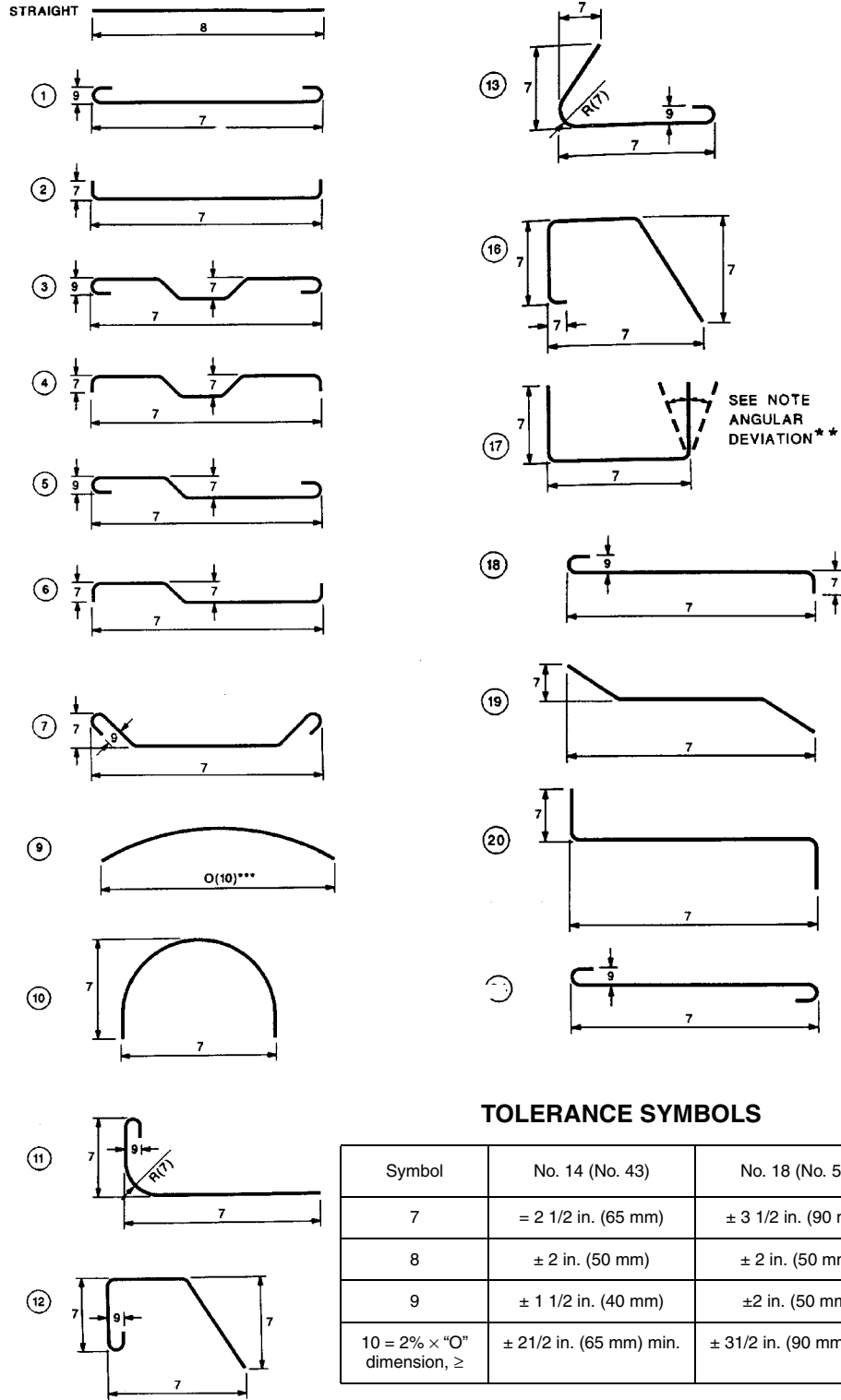

Note: All tolerances single plane as shown.
 *Saw-cut both ends—Overall length ± 1/2 in. (15 mm).
 **Angular deviation—Maximum ± 2 1/2 degrees or ± 1/2 in./ft (40 mm/m) on all 90 degree hooks and bends.
 ***If application of positive tolerance to Type 9 results in a chord length ≥ the arc or bar length, the bar may be shipped straight.

Fig. 9—Standard fabricating tolerances for bar sizes No. 14 and 18 (No. 43 and 57).

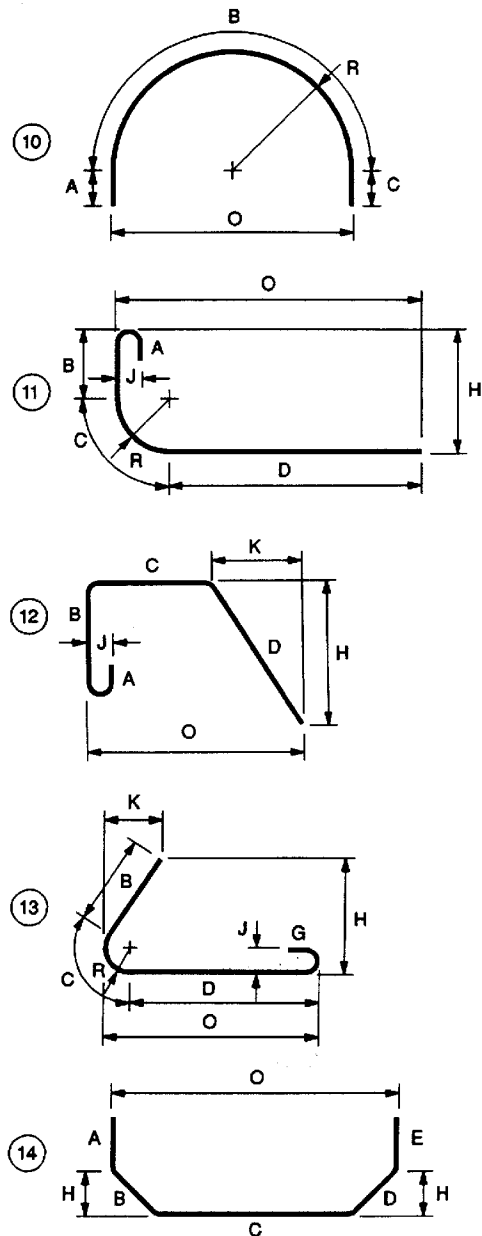
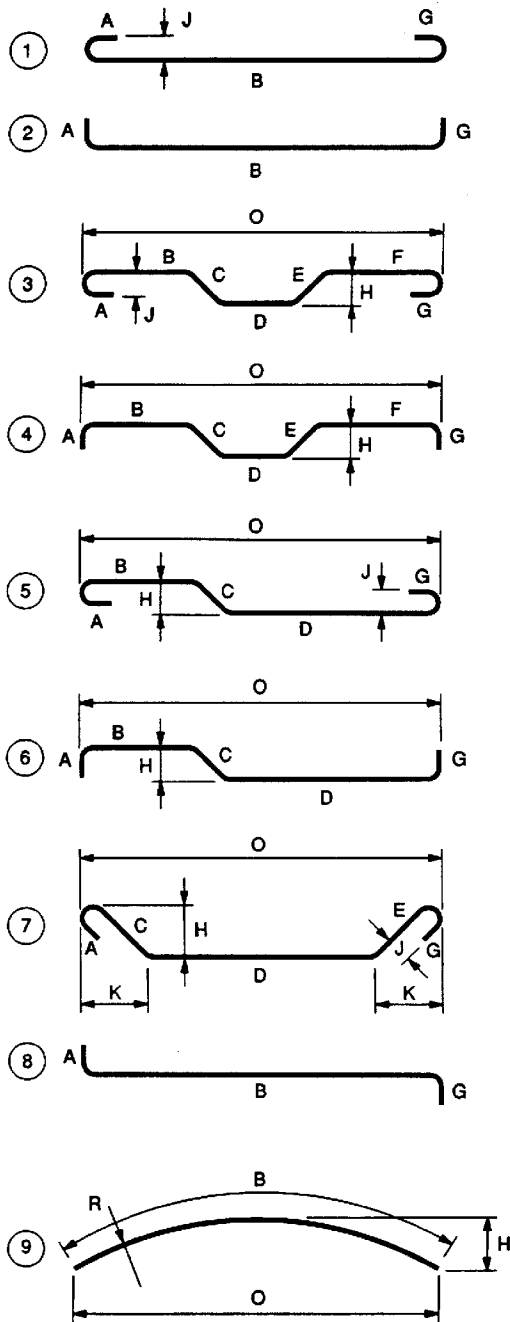

Notes:

1. All dimensions are out-to-out of bar except "A" and "G" on standard 180 and 135 degree hooks.
2. "J" dimensions on 180 degree hooks to be shown only where necessary to restrict hook size, otherwise ACI standard hooks are to be used.
3. Where "J" is not shown, "J" will be kept equal or less than "H" on Types 3, 5, and 22. Where "J" can exceed "H," it should be shown.
4. "H" dimension stirrups to be shown where necessary to fit within concrete.
5. Where bars are to be bent more accurately than standard fabricating tolerances, bending dimensions that require closer fabrication should have limits indicated.
6. Figures in circles show types.
7. For recommended diameter "D" of bends and hooks, see Section 3.7.1; for recommended hook dimensions, see Table 1.
8. Unless otherwise noted, diameter "D" is the same for all bends and hooks on a bar (except for Types 11 and 13).

Where slope differs from 45° dimensions, "H" and "K" must be shown.

ENLARGED VIEW SHOWING BAR BENDING DETAILS

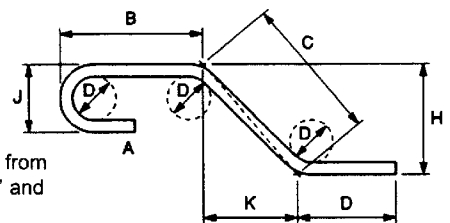
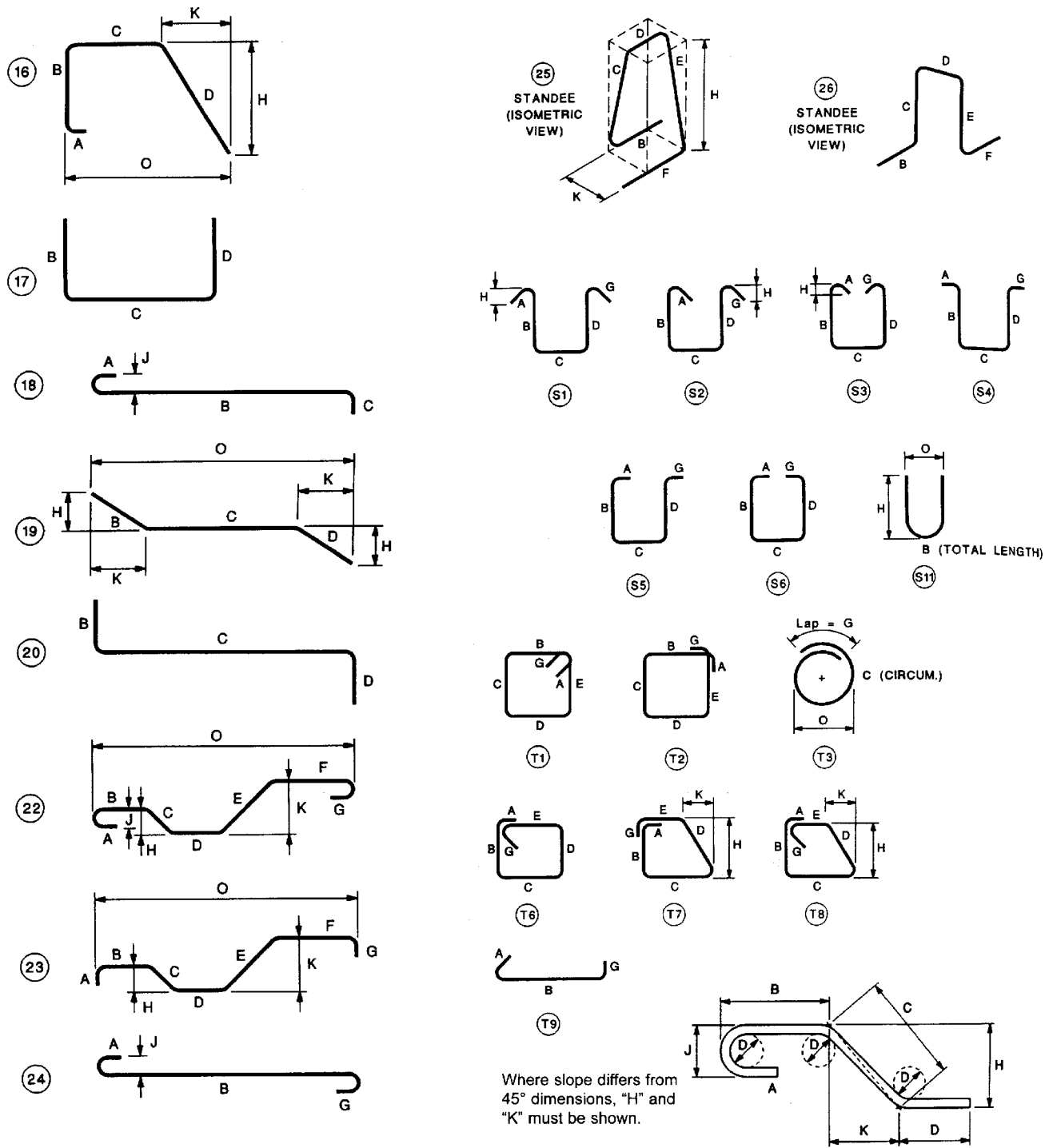

Fig. 10—Typical bar bends.



ENLARGED VIEW SHOWING BAR BENDING DETAILS

- Notes:
1. All dimensions are out-to-out of bar except "A" and "G" on standard 180 and 135 degree hooks.
 2. "J" dimensions on 180 degree hooks to be shown only where necessary to restrict hook size, otherwise ACI standard hooks are to be used.
 3. Where "J" is not shown, "J" will be kept equal or less than "H" on Types 3, 5, and 22. Where "J" can exceed "H," it should be shown.
 4. "H" dimension stirrups to be shown where necessary to fit within concrete.
 5. Where bars are to be bent more accurately than standard fabricating tolerances, bending dimensions that require closer fabrication should have limits indicated.

6. Figures in circles show types.
7. For recommended diameter "D" of bends and hooks, see Section 3.7.1; for recommended hook dimensions, see Table 1.
8. Type S1 through S6, S11, T1 through T3, T6 through T9: apply to bar sizes No. 3 through 8 (No. 10 through 25).
9. Unless otherwise noted, diameter "D" is the same for all bends and hooks on a bar (except for Types 11 and 13).

Fig. 10 (cont.)—Typical bar bends.

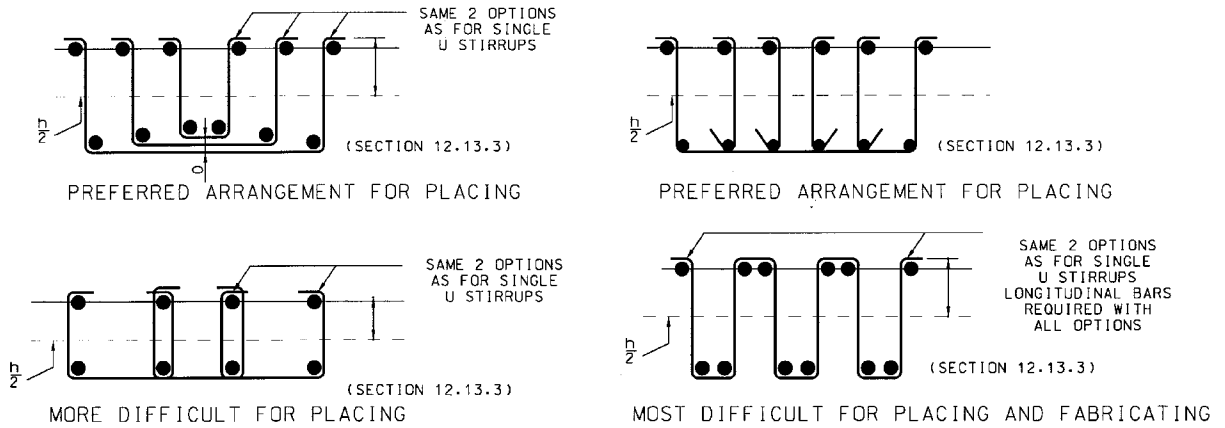
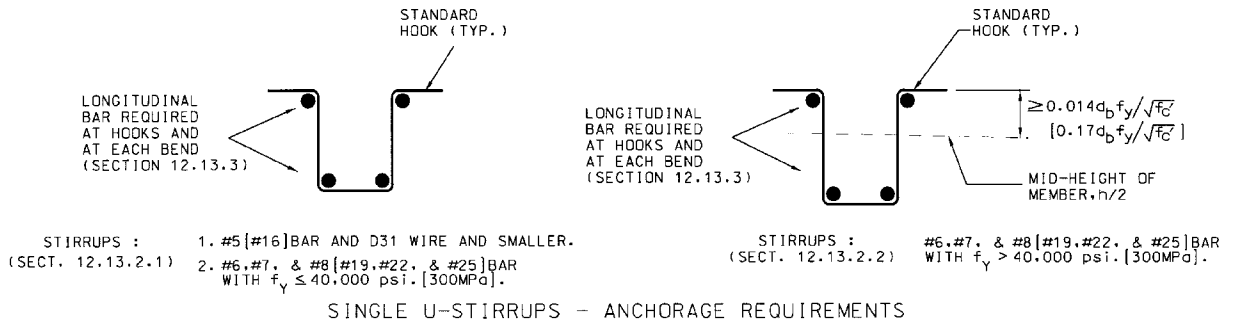

NOTE:SECTION NUMBERS REFER TO ACI 318 [318M].

Fig. 11—ACI requirements for anchorage of open stirrups.

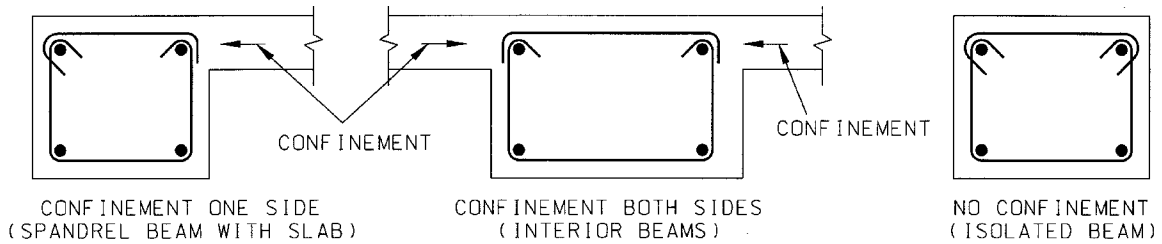

RECOMMENDED EFFECTIVE SINGLE TWO-PIECE CLOSED STIRRUPS—TORSION AND SHEAR

END ANCHORAGE OF BOTH VERTICAL LEGS AND TOP CLOSURE PER SECTION 12.13.2 OF ACI 318 [318M] FOR BAR SIZE VERSUS DIMENSIONS OF BEAM. LONGITUDINAL BARS REQUIRED FOR EACH CORNER.

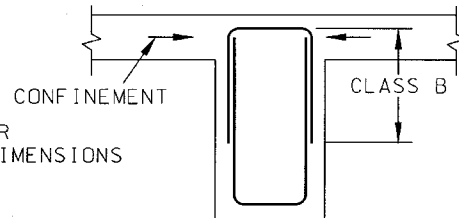

ALTERNATE FOR DEEP INTERIOR BEAMS

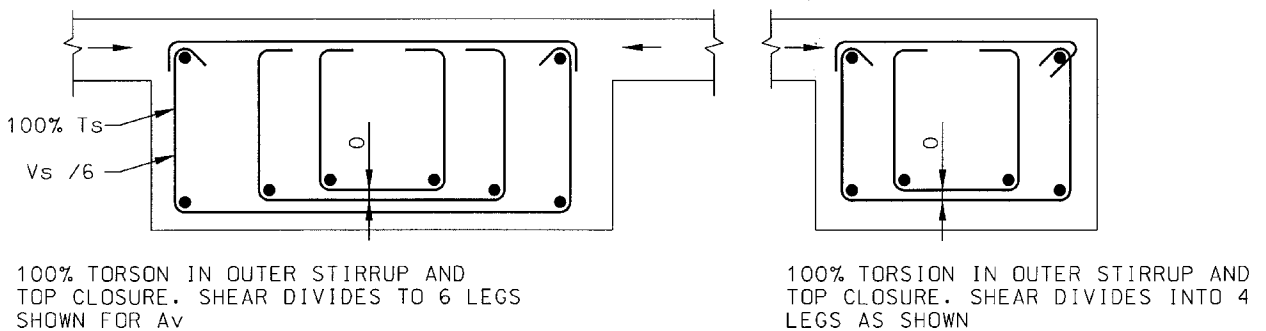
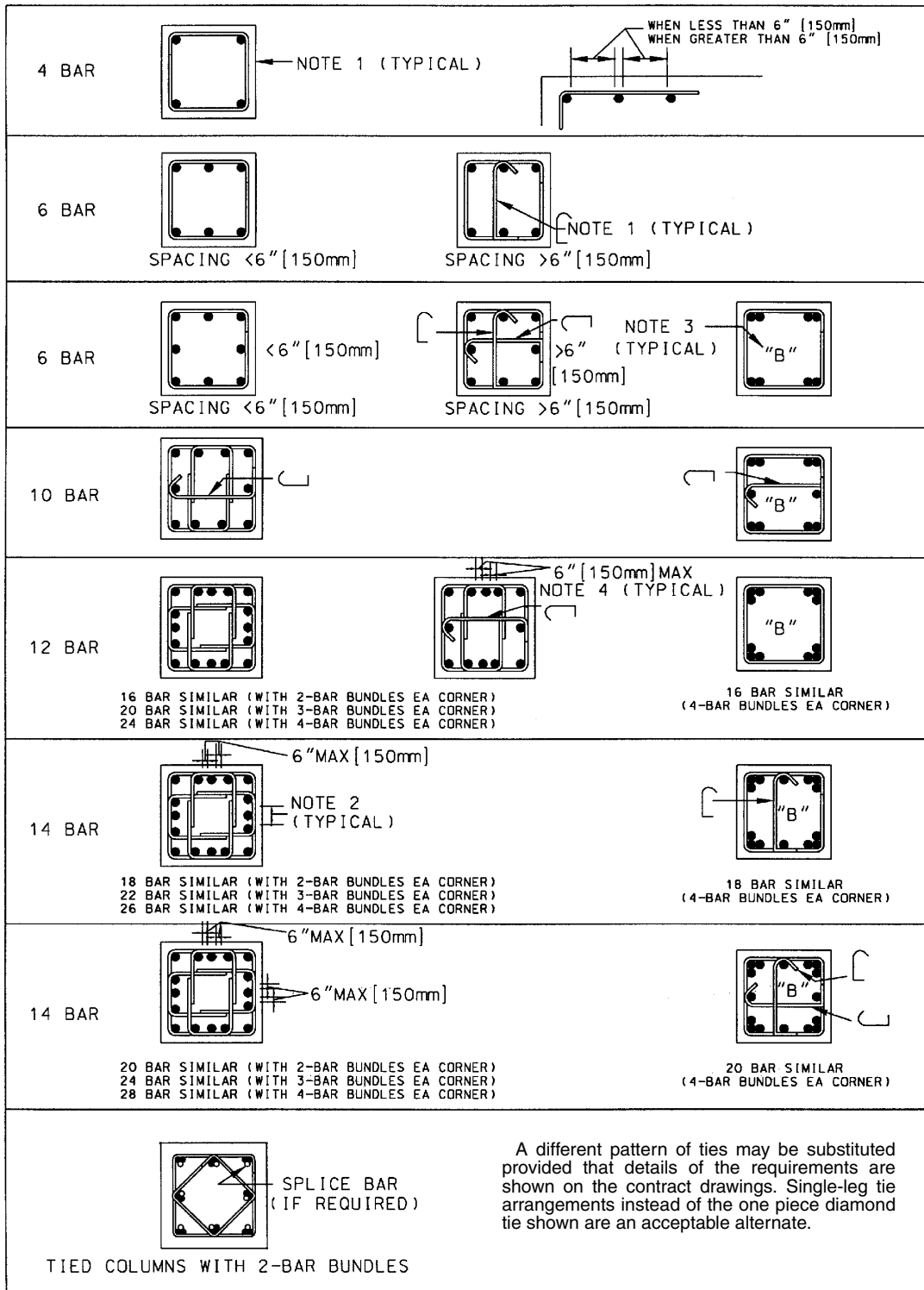

Fig. 12—Recommended two-piece closed single and multiple U-stirrups.



Notes:

1. Alternate position of hooks in placing successive sets of ties.
2. Minimum lap shall be 12 in. (300 mm).
3. B indicates bundled bars. Bundles shall not exceed four bars.
4. Elimination of tie for center bar in groups of three limits clear spacing to be 6 in. (150 mm) maximum. Unless otherwise specified, bars should be so grouped.
5. Note to Architect/Engineer: Accepted practice requires that design drawings show all requirements for splicing column verticals, that is, type of splice, lap length if lapped, location in elevation, and layout in cross section.
6. Note to Detailer: Dowel erection details are required for any design

- employing special large vertical bars, bundled vertical bars, staggered splices, or specially grouped vertical bars as shown.
7. Bars must be securely supported to prevent displacement during concreting.
8. Tie patterns shown may accommodate additional single bars between tied groups provided clear spaces between bars do not exceed 6 in. (150 mm).
9. Minimum cover to ties, 1 1/2 in. (40 mm) for nonprestressed cast-in-place concrete.
10. Spaces between corner bars and interior groups of three and between interior groups may vary to accommodate average spacing > 6 in. (150 mm).
11. For average spacing < 6 in. (150 mm), one untied bar may be located between each tied group of three and between a tied group and a corner bar.

Fig. 13—Standard column ties applicable for either preassembled cages or field erection.

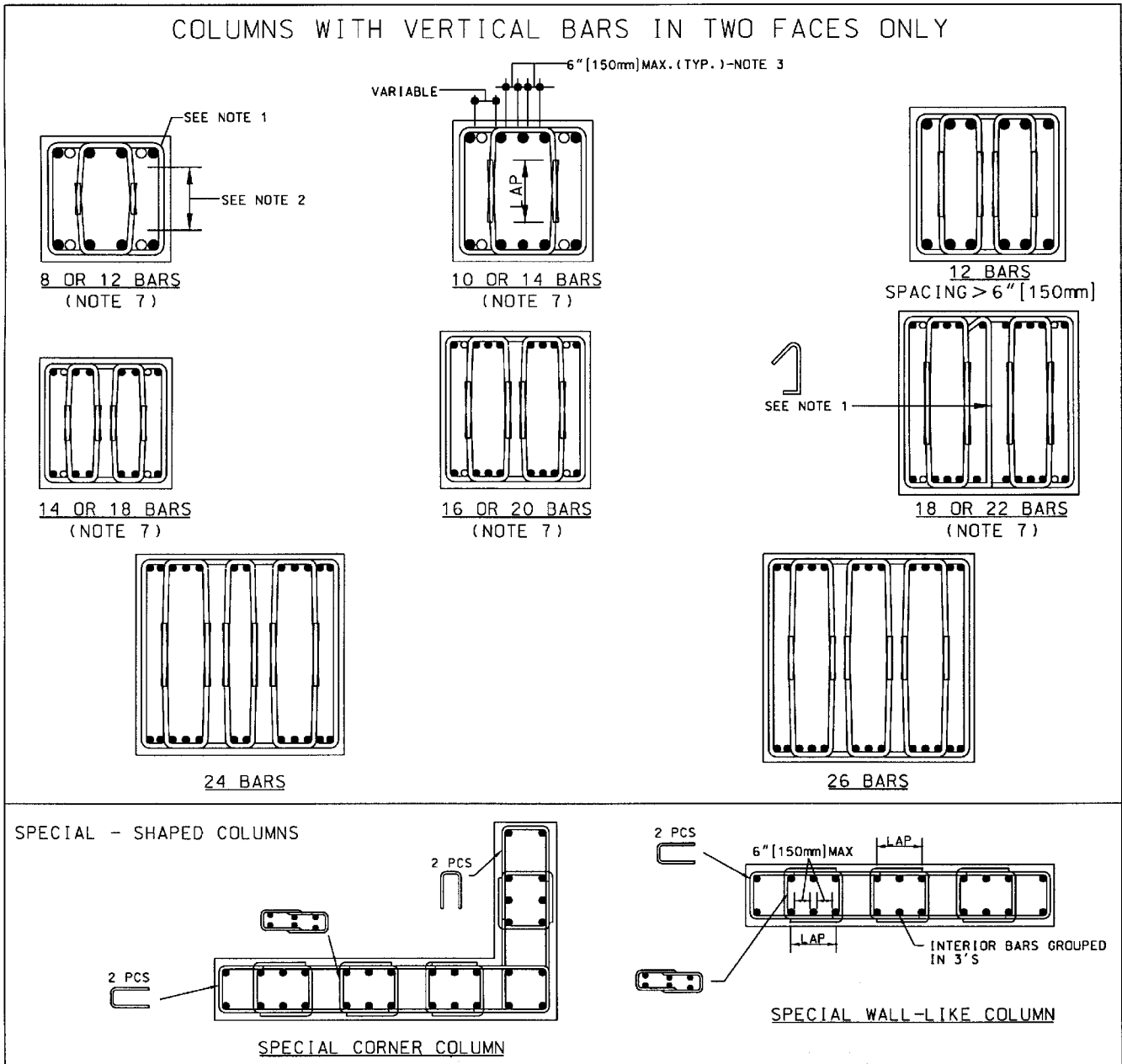

Notes:

1. Alternate position of hooks in placing successive sets of ties.
2. Minimum lap shall be 12 in. (300 mm).
3. Elimination of tie for center bar in groups of three limits clear spacing to be 6 in. (150 mm) maximum. Unless otherwise specified, bars should be so grouped.
4. Note to Architect/Engineer: Accepted practice requires that design drawings show all requirements for splicing column verticals, that is, type of splice, lap length if lapped, location in elevation, and layout in cross section.
5. Note to Detailer: Dowel erection details are required for any design employing special large vertical bars, bundled vertical bars, staggered splices, or specially grouped vertical bars as shown.

6. Bars must be securely supported to prevent displacement during concreting.
7. Bars shown as open circles may be accommodated provided clear spaces between bars do not exceed 6 in. (150 mm).
8. Tie patterns shown may accommodate additional single bars between tied groups provided clear spaces between bars do not exceed 6 in. (150 mm).
9. Minimum cover to ties, 1 1/2 in. (40 mm) for nonprestressed cast-in-place concrete.
10. Spaces between corner bars and interior groups of three and between interior groups may vary to accommodate average spacing > 6 in. (150 mm).
11. For average spacing < 6 in. (150 mm), one untied bar may be located between each tied group of three and between a tied group and a corner bar.

Fig. 14—Standard column ties applicable for either preassembled cages or field erection, special-shaped columns, and columns with bars in two faces only.

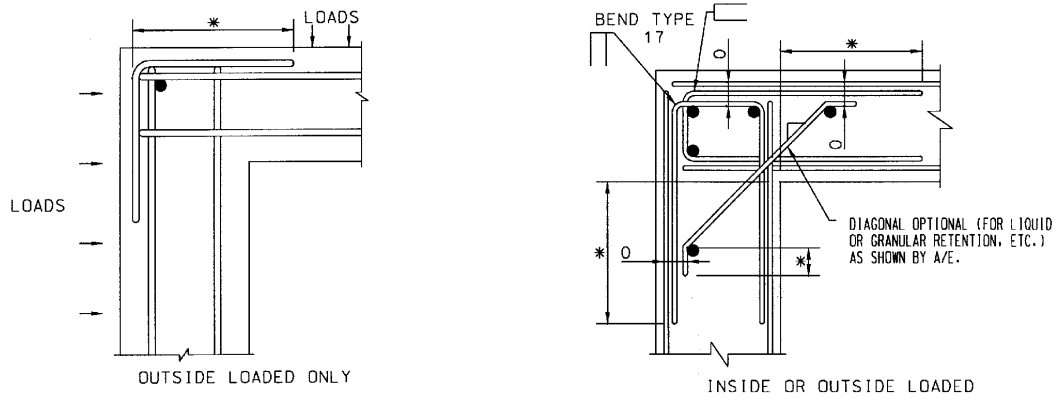

TYPICAL CORNER DETAILS

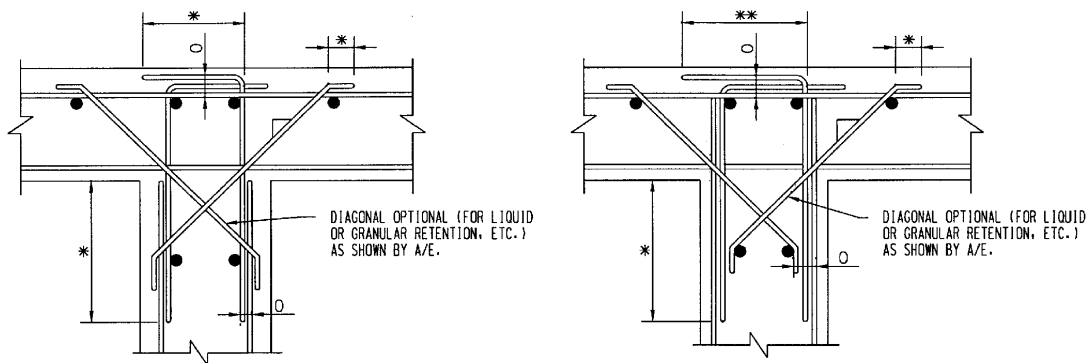

TYPICAL INTERSECTION DETAILS FOR DOUBLE CURTAIN REINFORCEMENT

Notes: all 90 degree bends as shown unless otherwise indicated on structural drawings. Vertical bars shown at hooks only. Bends are shown as sharp angles for clarity.

*This dimension must be shown or specified by the Architect/Engineer.

**If other than a standard 90 degree end hook, this dimension must be shown by the Architect/Engineer.

Fig. 15—Typical wall details shown in horizontal cross section.

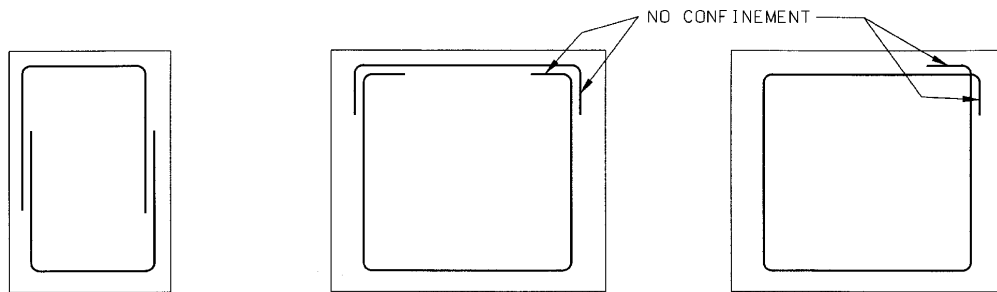

INEFFECTIVE CLOSED STIRRUP STYLES WHICH SHOWED PREMATURE FAILURE IN TESTS UNDER PURE TORSION

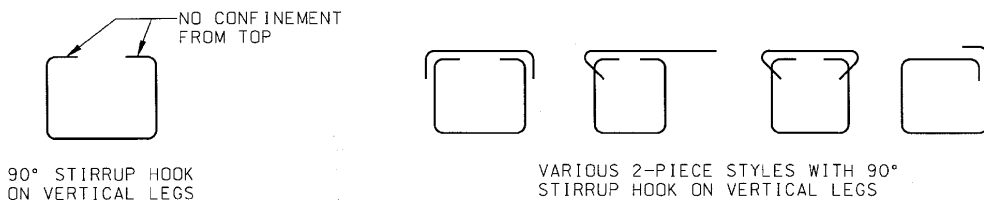

Notes: These styles are NOT RECOMMENDED for those members to be subjected to high torsional stress. Note lack of confinement when compared with similar members with confinement shown in Fig. 12.

Fig. 16—Not recommended; closed stirrup styles considered ineffective for members subjected to high torsion stress (based on tests by Collins and Mitchell).

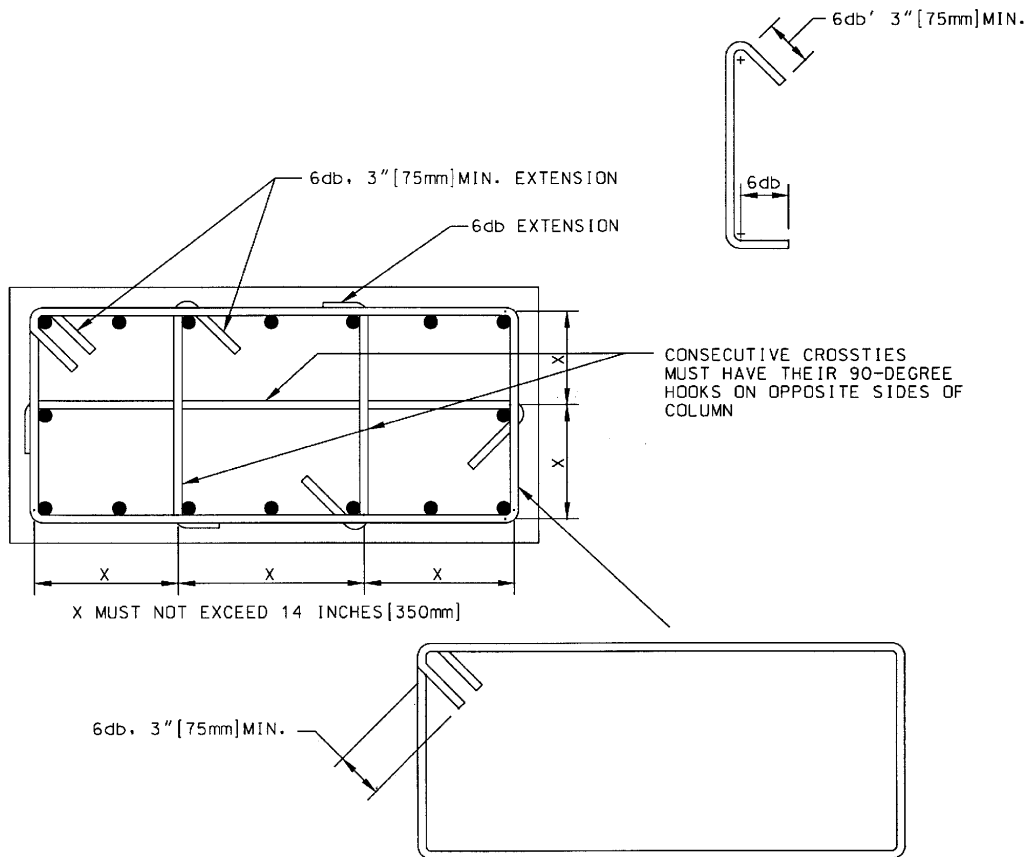
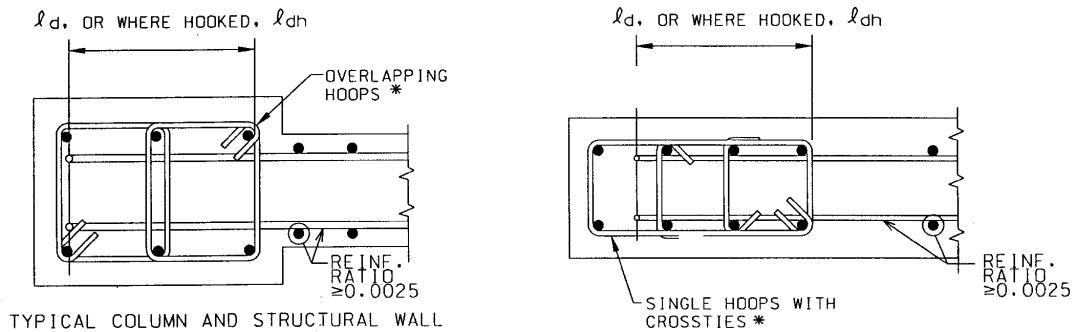

Fig. 17—Typical seismic resistant details: transverse reinforcement in columns.



FOR HORIZONTAL AND VERTICAL DIRECTIONS
 MAXIMUM SPACING AS PER ACI 21.4.4. 2 F.W.
 * SEE ACI 21.4.4 FOR TRANSVERSE REINFORCEMENT

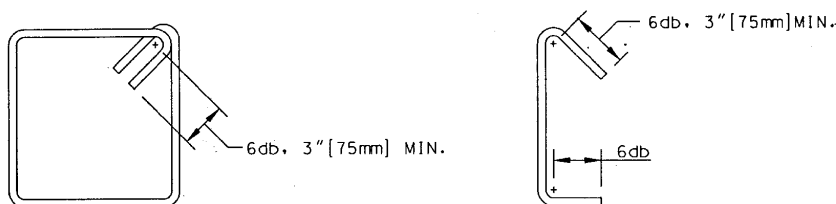

Fig. 18—Typical seismic-resistant details: boundary members.

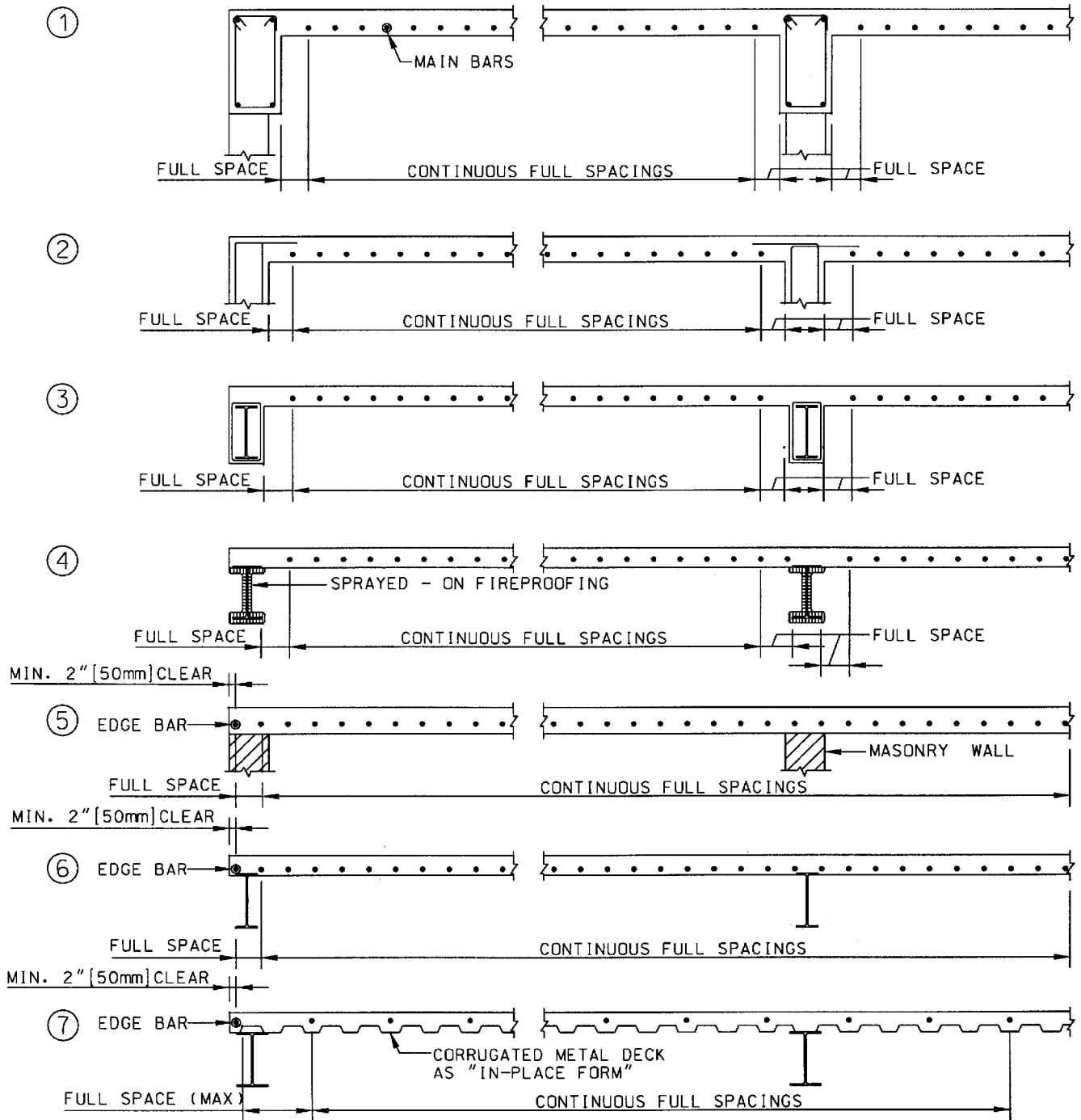

Fig. 19(a)—Location of first bar designated only by size and spacing, one-way slab main flexural reinforcing bars.

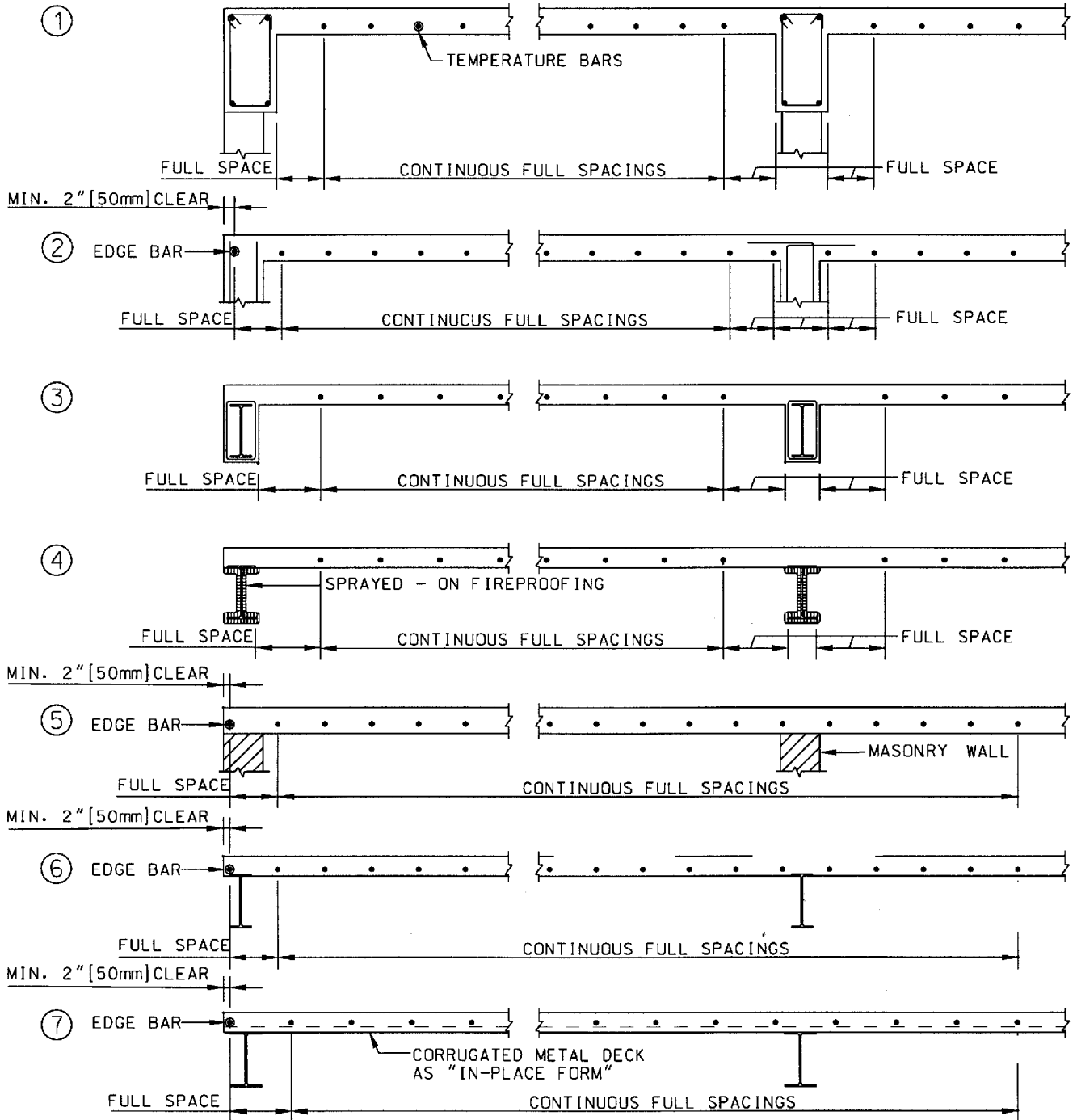

Fig. 19(b)—Location of first bar designated only by size and spacing, one-way slab shrinkage and temperature reinforcing bars.

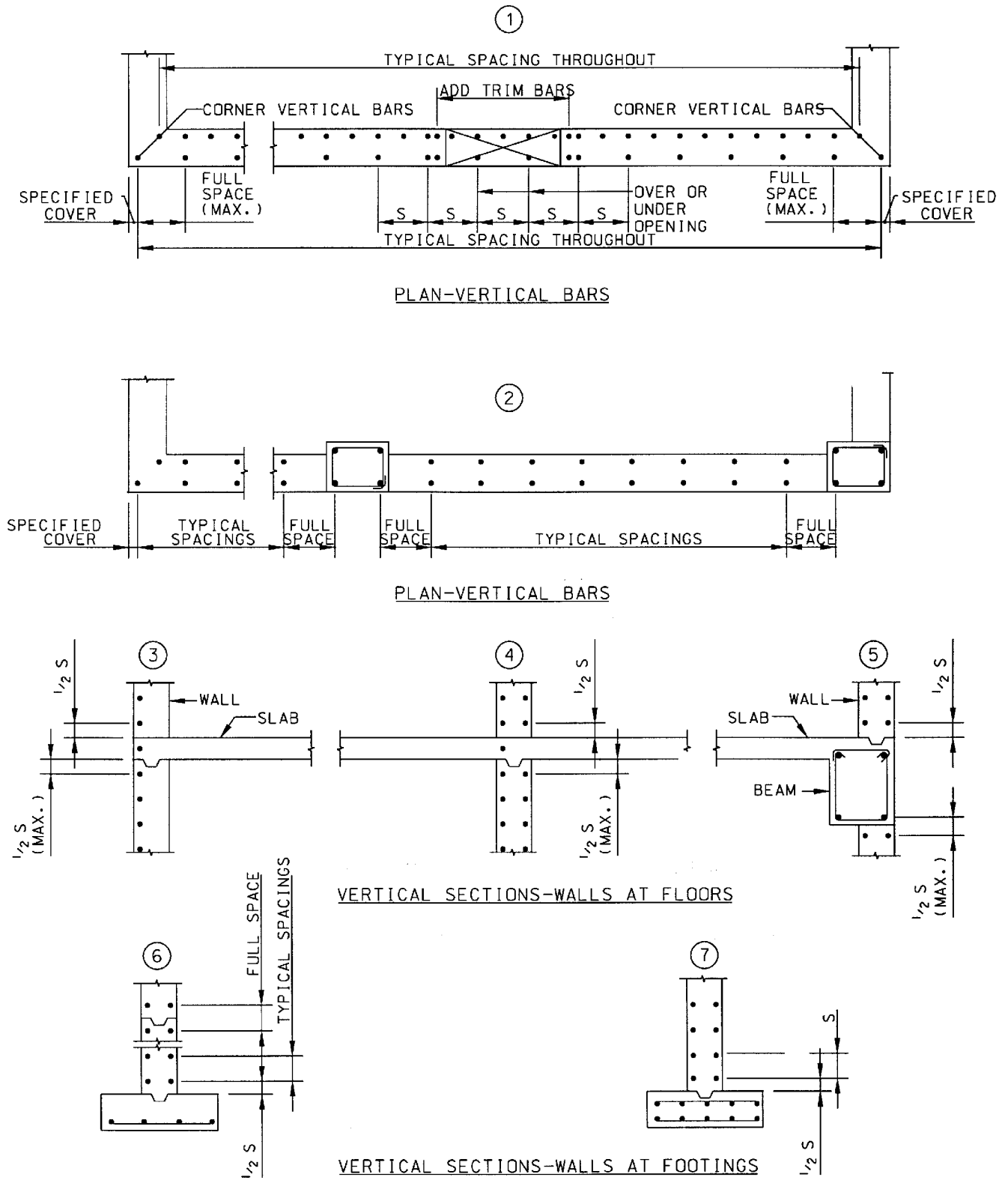
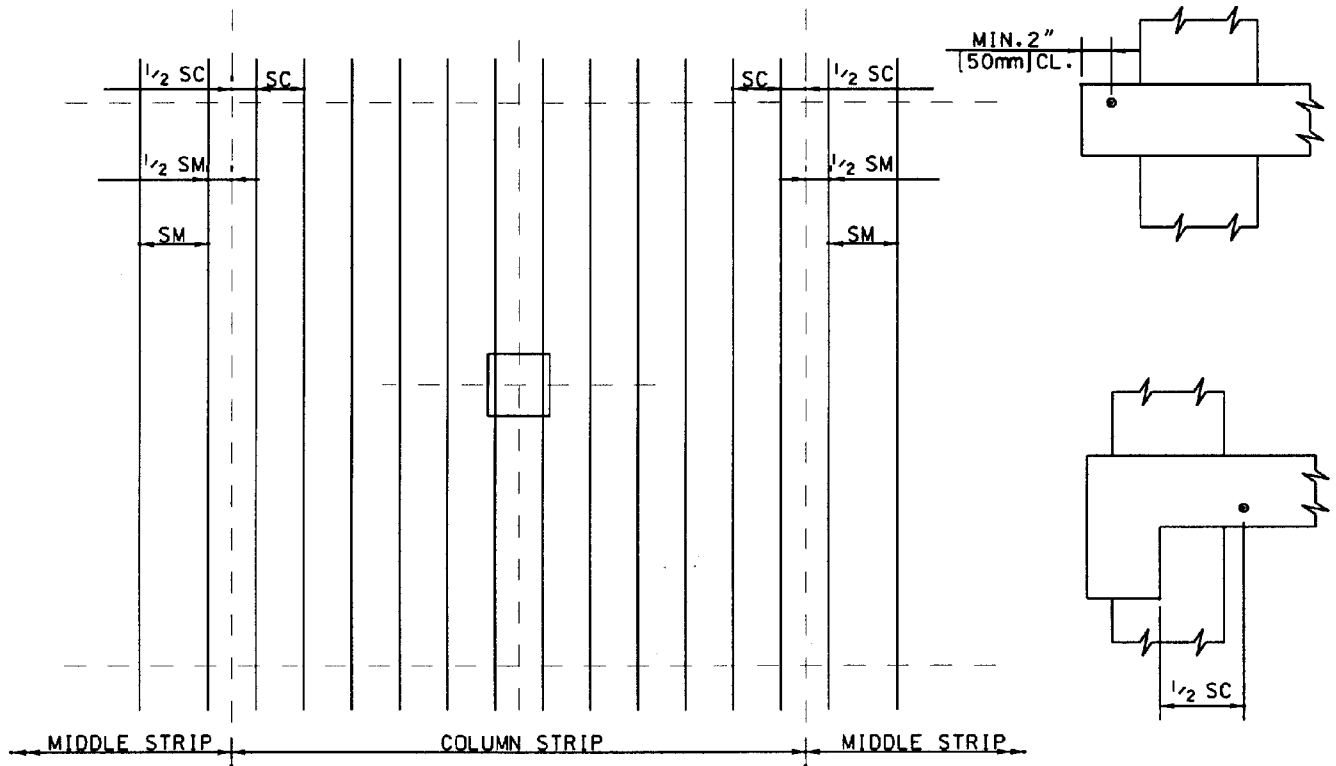

Fig. 19(c)—Location of first bar designated only by size and spacing, reinforcing bars in walls.



STANDARD SPACING UNLESS OTHERWISE DESIGNATED

EXCEPT FOR BARS PARALLEL TO SLAB EDGES, SPACE ALL REQUIRED BARS UNIFORMLY ACROSS COLUMN OR MIDDLE STRIPS STARTING AT ONE-HALF SPACING FROM EDGES OF COLUMN STRIPS, MIDDLE STRIPS, OR SPANDREL BEAMS. SPACE THE FIRST BARS PARALLEL TO SLAB EDGES WITH MINIMUM 2 IN. [50mm] CLEAR COVER. WHEN STRUCTURAL DRAWING DESIGNATES SEPARATELY A NUMBER OF BARS TO BE UNIFORMLY SPACED AND A NUMBER TO BE CONCENTRATED ABOUT THE COLUMN CENTERLINE, START THE UNIFORMLY SPACED BARS AT ONE-HALF SPACING FROM THE EDGES OF THE COLUMN STRIP

Fig. 19(d)—Location of first bar designated only by size and spacing, two-way slab reinforcing bars.

Table 1—Standard hooks: All specific sizes recommended meet minimum requirements of ACI 318

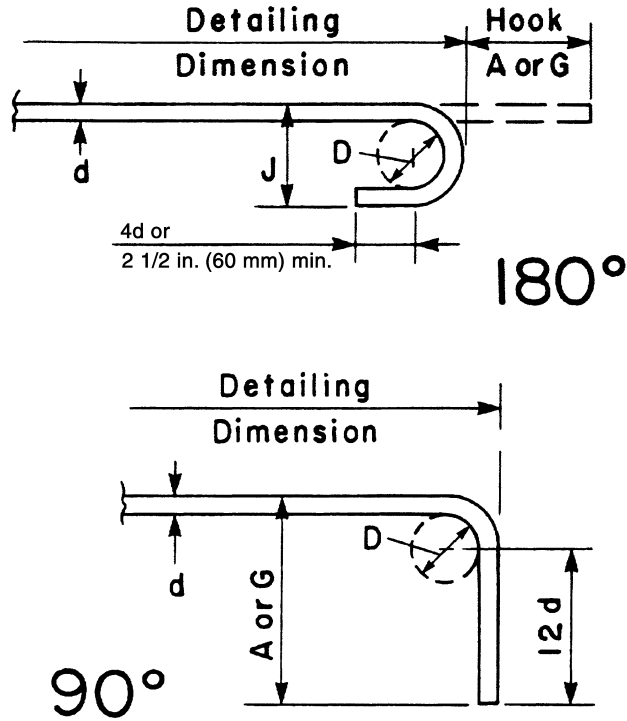

RECOMMENDED END HOOKS
All grades
D = Finished bend diameters

Bar size, No.	D,* in (mm)	180 degree hook		90 degree hook
		A or G, ft-in (mm)	J, ft-in. (mm)	A or G, ft-in. (mm)
3 (10)	2 1/4 (60)	5 (125)	3 (80)	6 (155)
4 (13)	3 (80)	6 (155)	4 (105)	8 (200)
5 (16)	3 3/4 (95)	7 (180)	5 (130)	10 (250)
6 (19)	4 1/2 (115)	8 (205)	6 (155)	1-0 (300)
7 (22)	5 1/4 (135)	10 (250)	7 (175)	1-2 (375)
8 (25)	6 (155)	11 (275)	8 (205)	1-4 (425)
9 (29)	9 1/2 (240)	1-3 (375)	11 3/4 (300)	1-7 (475)
10 (32)	10 3/4 (275)	1-5 (425)	1-1 1/4 (335)	1-10 (550)
11 (36)	12 (305)	1-7 (475)	1-2 3/4 (375)	2-0 (600)
14 (43)	18 1/4 (465)	2-3 (675)	1-9 3/4 (550)	2-7 (775)
18 (57)	24 (610)	3-0 (925)	2-4 1/2 (725)	3-5 (1050)

*Finished bend diameters include “spring back” effect when bars straighten out slightly after being bent and are slightly larger than minimum bend diameters in 3.7.2.

Table 1(cont.)—Standard hooks: All specific sizes recommended meet minimum requirements of ACI 318

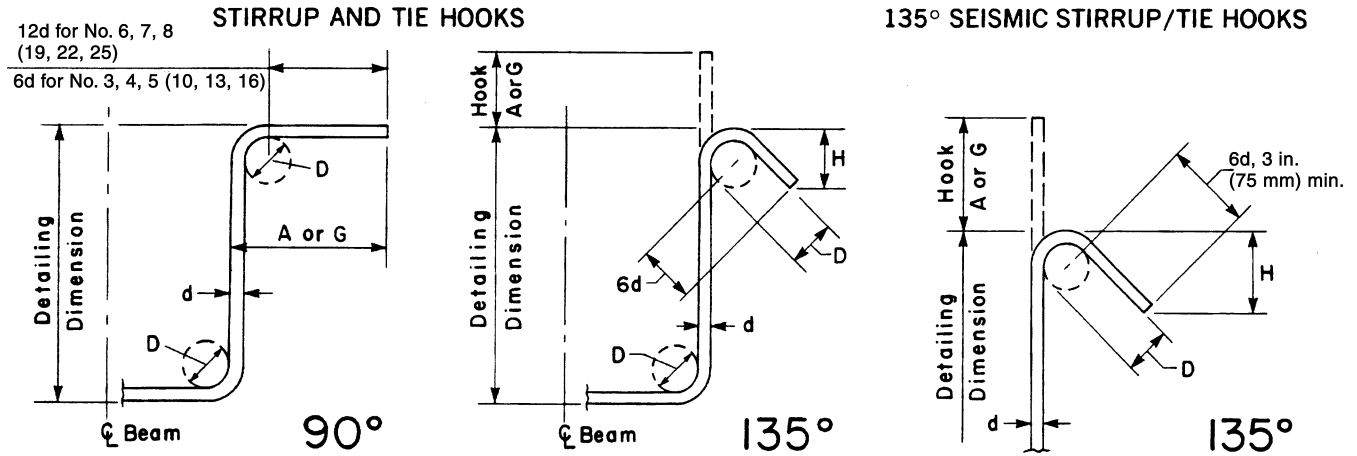

**STIRRUP
(TIES SIMILAR)
STIRRUP AND TIE HOOK DIMENSIONS
ALL GRADES**

Bar size, No.	D,* in. (mm)	135 degree hook		
		90 degree hook Hook A or G, ft-in. (mm)	Hook A or G, ft-in. (mm)	H approx., ft-in. (mm)
3 (10)	1 1/2 (40)	4 (105)	4 (105)	2 1/2 (65)
4 (13)	2 (50)	4 1/2 (115)	4 1/2 (115)	3 (80)
5 (16)	2 1/2 (65)	6 (155)	5 1/2 (140)	3 3/4 (95)
6 (19)	4 1/2 (115)	1-0 (305)	8 (205)	4 1/2 (115)
7 (22)	5 1/4 (135)	1-2 (355)	9 (230)	5 1/4 (135)
8 (25)	6 (155)	1-4 (410)	10 1/2 (270)	6 (155)

**135 DEGREE SEISMIC STIRRUP/TIE
HOOK DIMENSIONS
ALL GRADES**

Bar size, No.	D,* in. (mm)	135 degree hook	
		Hook A or G, ft-in. (mm)	H approx., ft-in. (mm)
3 (10)	1 1/2 (40)	4 1/4 (110)	3 (80)
4 (13)	2 (50)	4 1/2 (115)	3 (80)
5 (16)	2 1/2 (65)	5 1/2 (140)	3 3/4 (95)
6 (19)	4 1/2 (115)	8 (205)	4 1/2 (115)
7 (23)	5 1/4 (135)	9 (230)	5 1/4 (135)
8 (25)	6 (155)	10 1/2 (270)	6 (155)

*Finished bend diameters include "spring back" effect when bars straighten out slightly after being bent and are slightly larger than minimum bend diameters in 3.7.2.